

LIFTING CAPACITIES

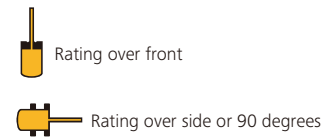
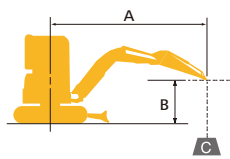

A – Reach from swing centerline for arm top  
 B – Arm top height above/below ground  
 C – Lifting capacities in pounds (kilograms)  
 Shoe: Rubber shoe Dozer blade: Down  
 \* Max. discharge pressure: 3,335 psi (23.0 MPa)

SK55SRX Cab		Long Arm: 6' 4" (1.92 m), Without bucket										Shoe: 15.7" (400 mm) Heavy Counterweight		At Max. Reach	Radius	
B	A	5 ft (1.5 m)		7.5 ft (2.3 m)		10 ft (3.0 m)		12.5 ft (3.8 m)		15 ft (4.6 m)		17.5 ft (5.3 m)				
15 ft (4.6 m)	lb (kg)								*1,830 (830)	*1,830 (830)			*2,040 (920)	*2,040 (920)	13' 11" (4.26 m)	
12.5 ft (3.8 m)	lb (kg)								*1,760 (790)	*1,760 (790)	*1,940 (870)	*1,940 (870)	*2,040 (920)	1,870 (840)	16' 0" (4.88 m)	
10 ft (3.0 m)	lb (kg)								*1,960 (880)	*1,960 (880)	*1,990 (900)	*1,990 (900)	*2,080 (940)	1,640 (740)	17' 4" (5.29 m)	
7.5 ft (2.3 m)	lb (kg)					*2,690 (1,220)	*2,690 (1,220)	*2,370 (1,070)	*2,370 (1,070)	*2,190 (990)	2,030 (920)	*2,120 (960)	1,600 (720)	*2,130 (960)	1,510 (680)	18' 2" (5.53 m)
5 ft (1.5 m)	lb (kg)					*3,790 (1,710)	3,550 (1,610)	*2,890 (1,310)	2,570 (1,160)	*2,470 (1,120)	1,980 (890)	*2,250 (1,020)	1,570 (710)	*2,190 (990)	1,440 (650)	18' 6" (5.65 m)
2.5 ft (0.8 m)	lb (kg)					*4,720 (2,140)	3,380 (1,530)	*3,390 (1,530)	2,470 (1,120)	*2,740 (1,240)	1,920 (870)	*2,380 (1,070)	1,540 (690)	*2,270 (1,020)	1,430 (640)	18' 6" (5.63 m)
G.L.	lb (kg)			*3,820 (1,730)	*3,820 (1,730)	*5,200 (2,350)	3,280 (1,480)	*3,720 (1,680)	2,410 (1,090)	*2,940 (1,330)	1,880 (850)	*2,460 (1,110)	1,520 (680)	*2,360 (1,070)	1,460 (660)	18' 0" (5.50 m)
-2.5 ft (-0.8 m)	lb (kg)	*3,770 (1,710)	*3,770 (1,710)	*5,530 (2,500)	5,080 (2,300)	*5,270 (2,390)	3,250 (1,470)	*3,840 (1,740)	2,370 (1,070)	*3,000 (1,360)	1,860 (840)			*2,460 (1,110)	1,560 (700)	17' 1" (5.22 m)
-5 ft (-1.5 m)	lb (kg)	*5,590 (2,530)	*5,590 (2,530)	*7,360 (3,330)	5,130 (2,320)	*4,980 (2,250)	3,260 (1,470)	*3,680 (1,660)	2,380 (1,070)	*2,810 (1,270)	1,870 (840)			*2,570 (1,160)	1,760 (790)	15' 8" (4.78 m)
-7.5 ft (-2.3 m)	lb (kg)	*7,890 (3,570)	*7,890 (3,570)	*6,150 (2,780)	5,220 (2,360)	*4,270 (1,930)	3,310 (1,500)	*3,100 (1,400)	2,420 (1,090)					*2,670 (1,210)	2,200 (990)	13' 5" (4.10 m)
-10 ft (-3.0 m)	lb (kg)	*6,430 (2,910)	*6,430 (2,910)	*3,890 (1,760)	*3,890 (1,760)									*2,660 (1,200)	*2,660 (1,200)	9' 9" (2.97 m)

SK55SRX Canopy		Long Arm: 6' 4" (1.92 m), Without bucket										Shoe: 15.7" (400 mm) Heavy Counterweight		At Max. Reach	Radius	
B	A	5 ft (1.5 m)		7.5 ft (2.3 m)		10 ft (3.0 m)		12.5 ft (3.8 m)		15 ft (4.6 m)		17.5 ft (5.3 m)				
15 ft (4.6 m)	lb (kg)								*1,830 (830)	*1,830 (830)			*2,040 (920)	*2,040 (920)	13' 11" (4.26 m)	
12.5 ft (3.8 m)	lb (kg)								*1,760 (790)	*1,760 (790)	*1,940 (870)	*1,940 (870)	*2,040 (920)	1,830 (830)	16' 0" (4.88 m)	
10 ft (3.0 m)	lb (kg)								*1,960 (880)	*1,960 (880)	*1,990 (900)	*1,990 (900)	*2,080 (940)	1,600 (720)	17' 4" (5.29 m)	
7.5 ft (2.3 m)	lb (kg)					*2,690 (1,220)	*2,690 (1,220)	*2,370 (1,070)	*2,370 (1,070)	*2,190 (990)	1,980 (890)	*2,120 (960)	1,560 (700)	*2,130 (960)	1,470 (660)	18' 2" (5.53 m)
5 ft (1.5 m)	lb (kg)					*3,790 (1,710)	3,470 (1,570)	*2,890 (1,310)	2,510 (1,130)	*2,470 (1,120)	1,930 (870)	*2,250 (1,020)	1,530 (690)	*2,190 (990)	1,400 (630)	18' 6" (5.65 m)
2.5 ft (0.8 m)	lb (kg)					*4,720 (2,140)	3,300 (1,490)	*3,390 (1,530)	2,410 (1,090)	*2,740 (1,240)	1,870 (840)	*2,380 (1,070)	1,510 (680)	*2,270 (1,020)	1,390 (630)	18' 6" (5.63 m)
G.L.	lb (kg)			*3,820 (1,730)	*3,820 (1,730)	*5,200 (2,350)	3,200 (1,450)	*3,720 (1,680)	2,350 (1,060)	*2,940 (1,330)	1,830 (830)	*2,460 (1,110)	1,480 (670)	*2,360 (1,070)	1,420 (640)	18' 0" (5.50 m)
-2.5 ft (-0.8 m)	lb (kg)	*3,770 (1,710)	*3,770 (1,710)	*5,530 (2,500)	4,960 (2,240)	*5,270 (2,390)	3,170 (1,430)	*3,840 (1,740)	2,310 (1,040)	*3,000 (1,360)	1,810 (820)			*2,460 (1,110)	1,520 (680)	17' 1" (5.22 m)
-5 ft (-1.5 m)	lb (kg)	*5,590 (2,530)	*5,590 (2,530)	*7,360 (3,330)	5,000 (2,260)	*4,980 (2,250)	3,180 (1,440)	*3,680 (1,660)	2,320 (1,050)	*2,810 (1,270)	1,820 (820)			*2,570 (1,160)	1,720 (780)	15' 8" (4.78 m)
-7.5 ft (-2.3 m)	lb (kg)	*7,890 (3,570)	*7,890 (3,570)	*6,150 (2,780)	5,090 (2,300)	*4,270 (1,930)	3,230 (1,460)	*3,100 (1,400)	2,360 (1,070)					*2,670 (1,210)	2,140 (970)	13' 5" (4.10 m)
-10 ft (-3.0 m)	lb (kg)	*6,430 (2,910)	*6,430 (2,910)	*3,890 (1,760)	*3,890 (1,760)									*2,660 (1,200)	*2,660 (1,200)	9' 9" (2.97 m)

**Note about lifting chart**

- Do not attempt to lift or hold any load that is greater than these lifting capacities at their specified lift point radius and heights. Weight of all accessories must be deducted from the above lifting capacities.
- Lifting capacities are based on machine standing on level, firm, and uniform ground. User must make allowance for job conditions such as soft or uneven ground, out of level conditions, side loads, sudden stopping of loads, hazardous conditions, experience of personnel, etc.
- Arm bucket pin, without bucket is defined as lift point.
- The above lifting capacities are in compliance with SAE J15067. They do not exceed 87 % of hydraulic lifting capacity or 75 % of tipping load. Lifting capacities marked with an asterisk (\*) are limited by hydraulic capacity rather than tipping load.
- Operator should be fully acquainted with the Operator's and Maintenance Instructions before operating this machine. Rules for safe operation of equipment should be adhered to at all times.
- Lifting capacities apply to only machines as originally manufactured and normally equipped by KOBELCO CONSTRUCTION MACHINERY CO., LTD.

**Note:** This catalog may contain attachments and optional equipment that are not available in your area. And it may contain photographs of machines with specifications that differ from those of machines sold in your areas. Please consult your nearest KOBELCO distributor for those items you require. Due to our policy of continuous product improvements all designs and specifications are subject to change without advance notice. Copyright by KOBELCO CONSTRUCTION MACHINERY CO., LTD. No part of this catalog may be reproduced in any manner without notice.

**KOBELCO CONSTRUCTION MACHINERY U.S.A. INC.**

22350 Merchants Way Katy, TX 77449  
<http://www.kobelco-usa.com/>

Inquiries To:

SK45SRX/55SRX-6E-NA-301-1712001

**MINI EXCAVATORS**  
**SK45SRX**  
**SK55SRX**



**DRIVEN BY PASSION**

Full-Size Performance, Short-Radius Agility and Quiet Operation

# COMPACT YET TOUGH MINI

Now KOBELCO has taken the next evolutionary step by packing even more digging power and practical performance features into the SK45SRX/SK55SRX while maintaining a short tail swing. The new Energy Conservation Mode saves even more fuel, and Kobelco's proprietary iNDr Cooling System ensures quiet operation, protection from dust, and easy maintenance. For greater operator comfort and safety, the rectangular cab design offers plenty of room and an unobstructed view. It all adds up to enhanced full-size performance, short-radius agility and a low-noise environment, with exceptional performance features and a full range of value-added functions.



The highly airtight engine compartment and the offset duct contribute to noise reduction. The iNDr filter fitted in front of the cooling system ensures easy cleaning. The muffler is designed to disperse and slow down the exhaust. The muffler exhaust is directed underneath for environmental protection. The SK45SRX/SK55SRX is an advanced machine which incorporates the iNDr system and eco-friendly system (iNDr+E).



# iNDr Cooling System

## The Revolutionary Integrated Noise and Dust Reduction Cooling System



The iNDr+E system on the SK45SRX/SK55SRX features air intake at the front of the machine and air exhaust underneath. It functions in the same way as the iNDr system on the SR series machines, but also directs the muffler exhaust underneath. Small holes on the muffler disperse and slow down the exhaust. The exhaust is further slowed down and cooled through the offset duct and then discharged into the atmosphere.

### iNDr Filter Blocks Out Dust

Outside air goes directly from the intake duct through the iNDr filter for dust removal, protecting vital engine coolers in adverse conditions.

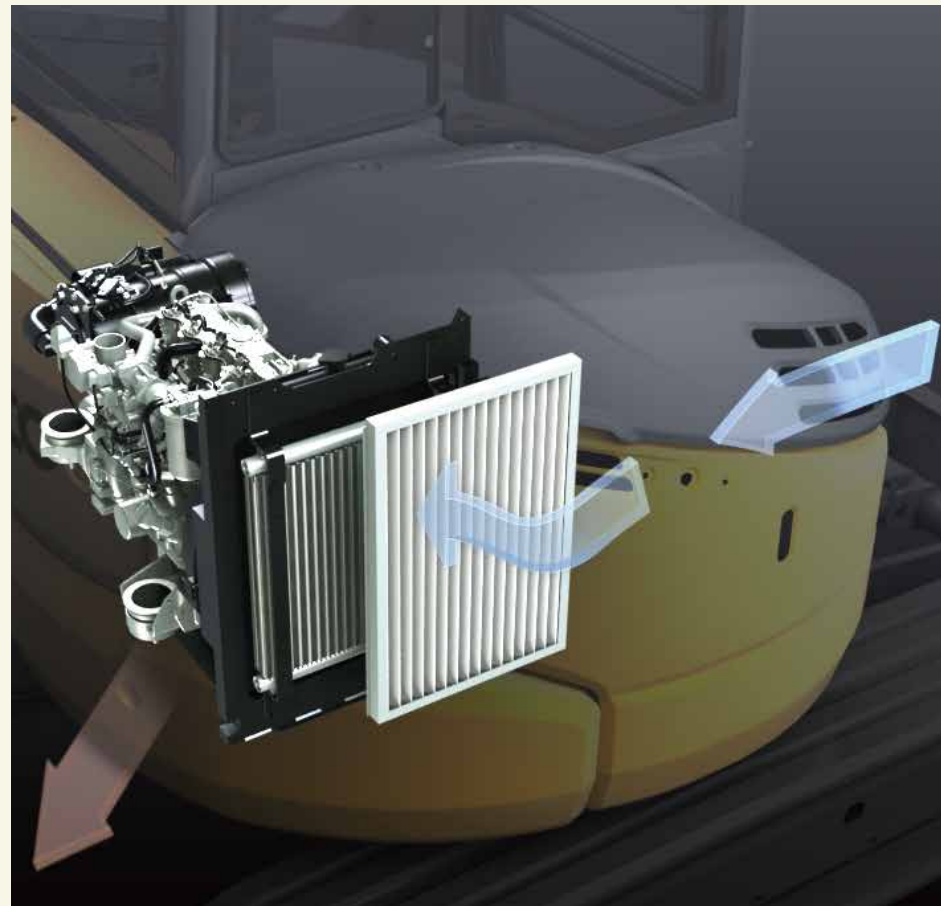

### Visual Checking and Easy Cleaning

Because the iNDr filter removes dust from the intake air, cooling components stay dirt-free and do not require regular cleaning. The iNDr filter itself can be easily removed and cleaned without the use of tools.



Offset duct slow down exhaust



Exhaust from the muffler and engine cooling fan.



Holes on the muffler disperse exhaust cooling it

### Ultimate Low Noise

KOBELCO's exclusive iNDr Cooling System delivers amazingly quiet operation. In fact, the SK45SRX/SK55SRX is 9 dB quieter than the previous models.

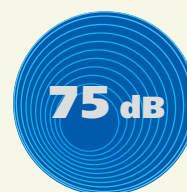

at 3'3" (1m) behind the machine and 4' 11" (1.5 m) height from ground level.

# Compact, yet, Big Performance

### Wide Working Range

A larger boom and arm are provided as standard equipment to ensure a wider working range.

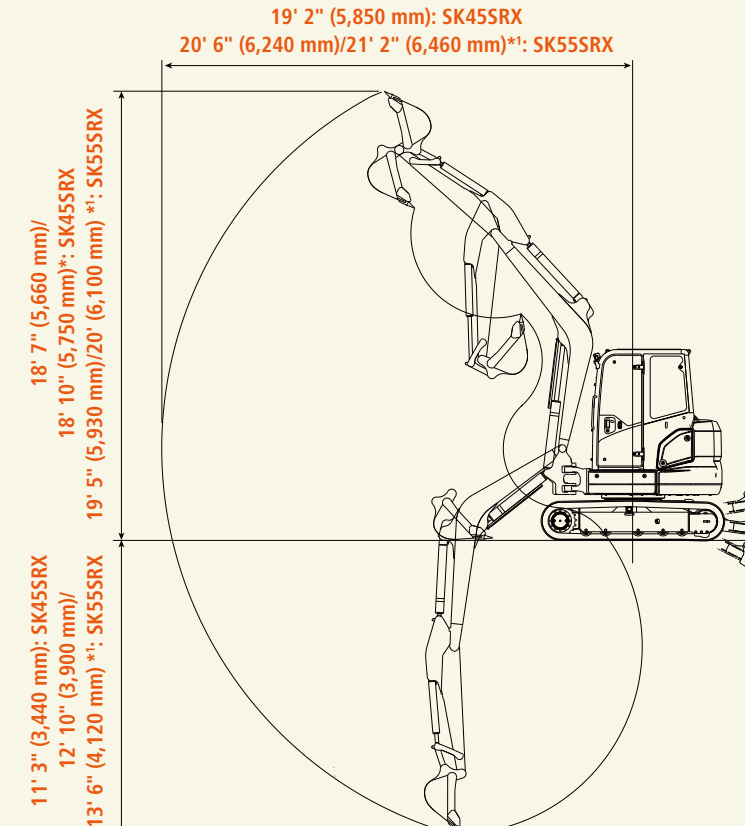

Figures marked with an asterisk (\*) show the value of canopy.  
\*: Figures show the value of long arm spec.

### Short Tail Swing

The compact tail swing improves operating efficiency in limited space.

**Tail overhang:**  
7.5" (190 mm)  
SK45SRX with Std. counterweight  
11.4" (290 mm)  
SK45SRX/SK55SRX with heavy counterweight

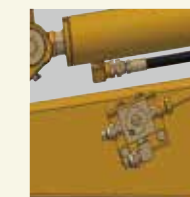

### N&B/thumb bracket switching valve

N&B/thumb bracket switching valve installed at tip of arm as standard. When changing between attachments, the required attachment can be selected by using the standard three way selector valve A/B/ and off.

### Easy Transportability

With an overall cab height of 8' 4" (2,530 mm), the machine is designed for easy transport.

### Energy Conservation Mode

The SK45SRX/SK55SRX adapts S mode which enables 25 percent less fuel consumption compared with the previous model.

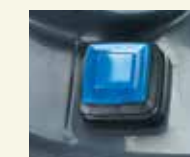

### One Touch Deceleration

The SK45SRX/SK55SRX features one-touch deceleration. It allows easy switching to an idling state, reducing the fuel consumption while the machine is at rest. Under complete control of the operator.



## Fast, Full-Powered Digging and Leveling

### Powerful Digging Performance

#### Integrated-Flow Pump System

During the digging operation, depending upon job condition, the machine provides additional flow to the boom, arm or bucket circuit, from the swing and dozer pump, to increase available input power to those functions. This drastically reduces cycle time and increases productivity.

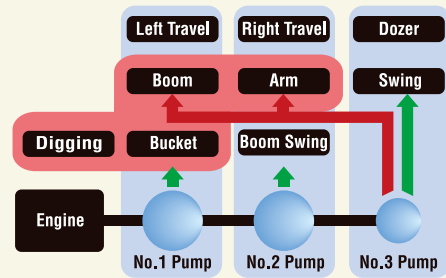

#### Large Capacity Engine

The large-capacity engine meets Tier IV final requirements and packs plenty power for outstanding hydraulic performance.



#### Diesel Particular Filter (DPF)

DP filter greatly reduce PM emission. Carbon builds up as soot on the diesel particulate filter and is burned off at high temperature.

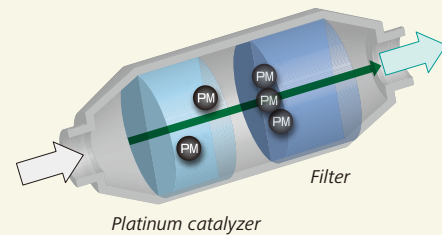

### More Travel Power

#### Large Capacity Travel Torque

The large capacity travel torque enables the machine to perform spin turn in low mode even when the dozer is pushing a heavy load.

#### Automatic Two-Speed Travel

If the machine is traveling in high speed and needs to turn, the motors automatically down shift for more power, and up shift for speed under light load.

#### Travel Switch

The travel lever is fitted with a button for easy switching to Hi-Mode travel.



### Powerful and Efficient Dozer Performance

#### New Dozer-Blade Shape

KOBELCO's unique blade design solves this problem by forming the earth into an arc that always falls forward. Because this prevents earth from falling behind the blade, only "one pass" is needed.

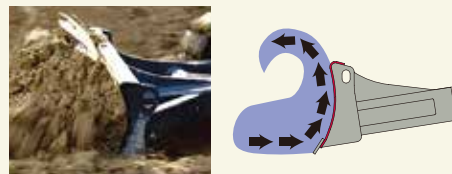

#### Hydraulic Pilot-Controlled Dozer Operation Lever

The dozer lever features hydraulic pilot control for precise control.



#### New 4-way Blade Option

Brand new from KOBELCO is a 4-way blade option available on the SK45SRX/SK55SRX. Built-in the same durability as the standard blade, this 4-way option provides 23 to 25 degrees of left and right angle movement for clearing, grading and back-filling. The 4-way blade gives you better control for following changing terrain and helps eliminate the windrowing effect that can occur with standard dozer blades



## Easy Daily Maintenance

Start-up checks are essential for safe and reliable machine operation. All start-up checks can be performed at ground level, with an easy-to-understand layout and cover design that simplify access and save time.

#### Easy Access to Engine Compartment



High-grade fuel filter

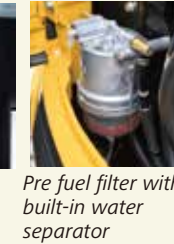

Pre fuel filter with built-in water separator



Air cleaner



#### Easy Access to Cooling Unit



iNDr filter



#### Easy Access Electrical Component Under the Seat



Hour meter



Fuel tank



Two-piece floor mats for easy washing

## Comfortable Work Environment

### Spacious Work Environment

The newly designed, rectangular cab is over 32 inches wide, with optimized control layout for comfortable, easy operation. A greater window area further improves visibility. A clear view is provided at the rear, and there's also more floor space, with a seat that slides further to ensure plenty of leg room.

### Easy Access

A wide-opening door and a left-hand tilting control console with safety lever that rises higher than before, make it much easier for operators enter and exit the cab.



### Work Lights

Work light is mounted under the boom to protect from damage.



### Skylight



### Plenty of Foot Room

Generous space below, eases pedal operation.

### Excellent Front Visibility

Wider front window ensures an open, panoramic view.



### Standard Pattern Changer

Standard pattern changer allows for increased utilization and flexibility to match operator preference.



### Color Liquid Crystal Monitor (Optional)

The color liquid crystal monitor is fitted as option. Operation data as well as the full range of machine-status data can readily be checked.



### Control Lever

Precise proportional controls are integrated into the joystick for ease of operation.



## Comfortable Operator's Cab Environment

### Suspension Seat **NEW**

The suspension seat offers a host of operator comforts whether on the job or at rest.



### Hammer for Emergency Exit



### Climate Control

The climate control system is located down and to the right of the seat, keeping the rear view clear.



Vents to send cooled air toward the operator if he desires.

### Opening/Closing Front Window

The front window features gas damper cylinders for smooth and easy opening and closing.



### Coat Hook



### Room Light



### Two-speaker FM/AM Radio with Station Select



## Operator Safety

### Reliable Cab Structure

The high-strength cab meets ROPS and FOPS standards for greater operator safety.



### Exclusive, Newly Designed ROPS/FOPS Canopy

The high-strength canopy meets ROPS and FOPS standards for greater operator safety.



Operator's Cab, Front Rock Guards for Cab or Canopy, available from KOBELCO Parts department.

\*Photo shows the Front Rock Guard for SK355R.



Factory order Boom and Arm, Hose Burst Valves are available as option.

# Reliable Construction

The boom, arm and swing bracket all have large cross-section designs for added attachment strength.

## Strong boom and arm

Boom to arm pins are retained to further support the boom point. Thick durable boom tip



## Bucket

Cast-iron idler link provide greater strength.



Plate type pin retainer prevents wear by rotation of the pin itself. Thick durable boom foot

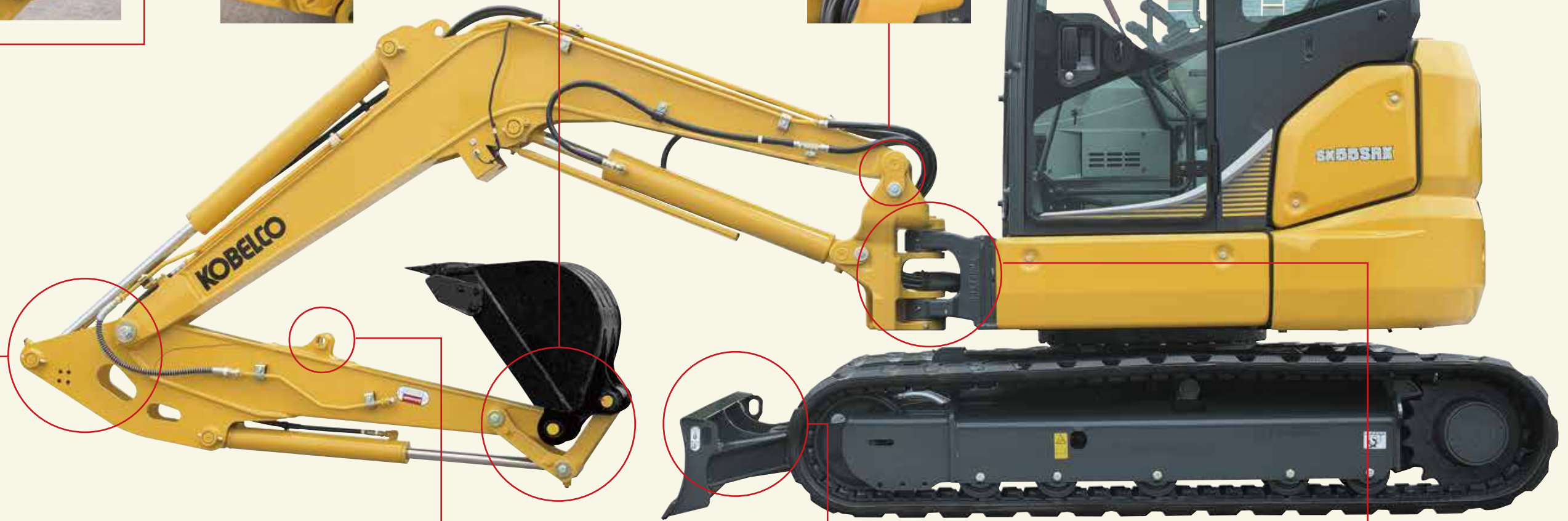

## Accumulator for Emergency Attachment Lowering



A newly installed accumulator allows the attachment to be safely lowered to the ground using in-cab controls in the event of an unexpected engine shut-down and class leading smooth operation.



Standard thumb mounting bracket



Dozer  
Box construction dozer supports provide greater strength.

## Swing bracket

Large, thick cast-iron swing bracket/front bracket.



## Hydraulic piping

The hydraulic piping is housed inside the swing bracket for protection.



## SPECIFICATIONS

GENERAL				
MODEL		SK45SRX		
Type		SK45SRX-6E		
Machine Mass	Cab	lbs (kg)	10,300 (4,670)	
	Canopy	lbs (kg)	10,030 (4,550)	
Bucket Capacity		cu ft (m³)	4.94 (0.14)	
Bucket Width (with side cutter)		ft-in (mm)	23.6" (600)	
Arm Length		ft-in (mm)	5' 1" (1.55)	
Bucket Digging Force (SAE)		lbf (kN)	7,000 (31.1)	
Arm Crowding Force (SAE)		lbf (kN)	11,128 (49.5): Two pin bucket 4,500 (19.9)	
ENGINE				
Model		YANMAR 4TNV88C-PYB		
Type		Water cooled, 4-cycle, 4-cylinder, direct injection, diesel engine (Tier IV final-compliant engine)		
Power Output	hp (kW)/rpm	37.4 (27.9)/2,400 (SAE NET)		
Max. Torque	lbf-ft (N-m)/rpm	97.3 (131.8)/1,560 (SAE NET)		
Displacement	cu in (L)	133.6 (2.189)		
Fuel Tank	US gal (L)	19.8 (75)		
HYDRAULIC SYSTEM				
Pump		Two variable displacement pumps+ two gear pumps (one for pilot)		
Max. Discharge Flow	US gpm (L/min)	2 x 13.2 (49.9), 8.9 (33.8), 2.9 (10.8)		
Relief Valve Setting	psi (MPa)	3,335 (23.0)		
Hydraulic Oil Tank (system)	US gal (L)	7.4 (27.9) (15.2 (57.7))		
TRAVEL SYSTEM				
Travel Motors		2 x axial-piston, two-step motors		
Parking Brake		Oil disc brake per motor		
Travel Speed (high/low)	mph (km/h)	2.5 (4.0) / 1.4 (2.2)		
Drawbar Pulling Force (SAE)	Cab	lbf (kN)	12,390 (55.1)	
	Canopy	lbf (kN)	12,400 (55.2)	
CRAWLER				
Shoe Width	in (mm)	15.7" (400)		
Ground Pressure	Cab	psi (kPa)	3.81 (26.3)	
	Canopy	psi (kPa)	3.71 (25.6)	
DOZER BLADE				
Width x Height	ft-in (mm)	6' 5" (1,960) x 1' 2" (345)		
Working Ranges (height/depth)	ft-in (mm)	1' 6" (465) x 1' 1" (335)		
SWING SYSTEM				
Swing Motor		Axial piston motor		
Parking Brake		Oil disc brake, hydraulic operated automatically		
Swing Speed	min <sup>-1</sup> (rpm)	8.5		
Tail Swing Radius	ft-in (mm)	3' 10" (1,170)		
Min. Front Swing Radius	Over the front	Cab	ft-in (mm)	7' 5" (2,250)
		Canopy	ft-in (mm)	7' 3" (2,210)
	At full boom swing	Cab	ft-in (mm)	6' 1" (1,850)
		Canopy	ft-in (mm)	5' 10" (1,790)
SIDE DIGGING MECHANISM				
Type		Boom swing		
Offset Angle	To the left	degree	70	
	To the right	degree	59	

## DIMENSIONS

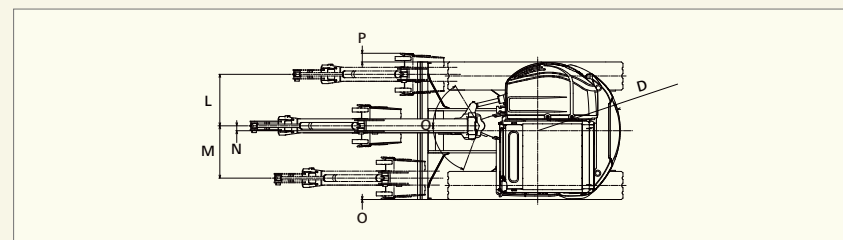
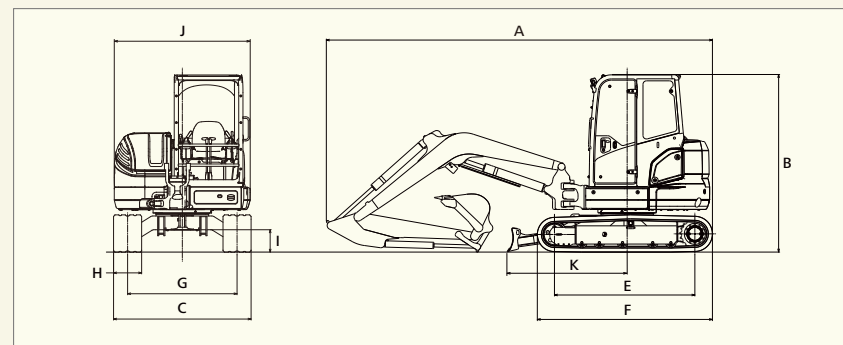

## WORKING RANGES

Unit: ft-in (mm)

Model	SK45SRX	
	Cab	Canopy
Arm length	5' 1" (1.55 m)	
a- Max. digging reach	19' 2" (5,850)	
b- Max. digging reach at ground level	18' 8" (5,700)	
c- Max. digging depth	11' 3" (3,440)	
d- Max. digging height	18' 7" (5,660)	18' 10" (5,750)
e- Max. dumping clearance	13' 5" (4,080)	13' 8" (4,160)
f- Min. dumping clearance	4' 11" (1,510)	5' 1" (1,560)
g- Max. vertical wall digging depth	9' 3" (2,820)	
h- Min. swing radius	7' 5" (2,250)	7' 3" (2,210)
i- Horizontal digging stroke at ground level	8' 8" (2,650)	
j- Dozer blade (height/depth)	1' 6" (465)/1' 1" (335)	

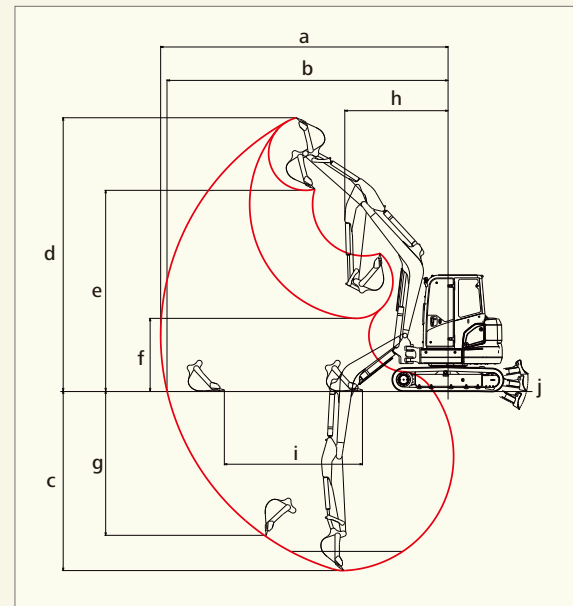

## HYDRAULIC P.T.O

Specification	Output Maximum Pressure PSI (MPa)	Max Flow US GPM, (lpm)	
		2,000 rpm	1,000 rpm
NGB	3,335 (23.0)	18.4 (69.8)	9.2 (34.9)
Rotary	3,190 (22.0)	7.5 (28.2)	3.7 (14.1)

Unit: ft-in (mm)

Model	SK45SRX	
A Overall length	17' 4" (5,280)	
B Overall height	8' 4" (2,530)	
C Overall width	6' 5" (1,960)	
D Tail swing radius (Std. counterweight)	3' 10" (1,170)	
E Tumbler distance	6' 7" (2,000)	
F Overall length of crawler	8' 2" (2,500)	
G Track gauge	5' 1" (1,560)	
H Shoe width	15.7" (400)	
I Ground clearance	12.6" (320)	
J Overall width of upperstructure	6' 4" (1,940)	
K Distance from dozer top to center of upperstructure	9' 7" (2,920)	

Unit: ft-in (mm)

Model	SK45SRX	
L Boom offset volume (right)	2' 5" (745)	
M Boom offset volume (left)	2' 5" (735)	
N Offset volume of boom center	2.8" (70)	
O Digging distance outside crawler shoe (right)	0	
P Digging distance outside crawler shoe (left)	4.9" (125)	
Q Boom swing angle (left/right)	70°/59°	

## LIFTING CAPACITIES

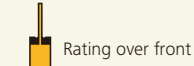
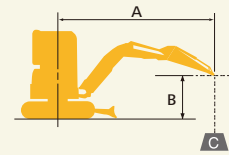

Rating over front



Rating over side or 90 degrees

A – Reach from swing centerline for arm top  
B – Arm top height above/below ground  
C – Lifting capacities in pounds (kilograms)  
Shoe: Rubber shoe Dozer blade: Down  
\* Max. discharge pressure: 3,335 psi (23.0 MPa)

SK45SR Cab	Standard Arm: 5' 1" (1.55 m) Without bucket		Shoe: 15.7" (400 mm)		Std. Counterweight		At Max. Reach		Radius
	5' (1.5 m)	7.5' (2.3 m)	10' (3.0 m)	12.5' (3.8 m)	15' (4.6 m)				
15 ft (4.6 m)	lb (kg)								10' 10" (3.31 m)
12.5 ft (3.8 m)	lb (kg)								13' 6" (4.13 m)
10 ft (3.0 m)	lb (kg)								15' 2" (4.62 m)
7.5 ft (2.3 m)	lb (kg)								16' 1" (4.91 m)
5 ft (1.5 m)	lb (kg)								16' 6" (5.04 m)
2.5 ft (0.8 m)	lb (kg)								16' 5" (5.02 m)
G. L.	lb (kg)								15' 11" (4.86 m)
-2.5 ft (-0.8 m)	lb (kg)								14' 11" (4.54 m)
-5 ft (-1.5 m)	lb (kg)								13' 1" (4.00 m)
-10 ft (-3.0 m)	lb (kg)								10' 2" (3.09 m)

SK45SR Canopy	Standard Arm: 5' 1" (1.55 m) Without bucket		Shoe: 15.7" (400 mm)		Std. Counterweight		At Max. Reach		Radius
	5' (1.5 m)	7.5' (2.3 m)	10' (3.0 m)	12.5' (3.8 m)	15' (4.6 m)				
15 ft (4.6 m)	lb (kg)								10' 10" (3.31 m)
12.5 ft (3.8 m)	lb (kg)								13' 6" (4.13 m)
10 ft (3.0 m)	lb (kg)								15' 2" (4.62 m)
7.5 ft (2.3 m)	lb (kg)								16' 1" (4.91 m)
5 ft (1.5 m)	lb (kg)								16' 6" (5.04 m)
2.5 ft (0.8 m)	lb (kg)								16' 5" (5.02 m)
G. L.	lb (kg)								15' 11" (4.86 m)
-2.5 ft (-0.8 m)	lb (kg)								14' 11" (4.54 m)
-5 ft (-1.5 m)	lb (kg)								13' 1" (4.00 m)
-10 ft (-3.0 m)	lb (kg)								10' 2" (3.09 m)

SK45SR Cab	Standard Arm: 5' 1" (1.55 m) Without bucket		Shoe: 15.7" (400 mm)		Add-on Counterweight		At Max. Reach		Radius
	5' (1.5 m)	7.5' (2.3 m)	10' (3.0 m)	12.5' (3.8 m)	15' (4.6 m)				
15 ft (4.6 m)	lb (kg)								10' 10" (3.31 m)
12.5 ft (3.8 m)	lb (kg)								13' 6" (4.13 m)
10 ft (3.0 m)	lb (kg)								15' 2" (4.62 m)
7.5 ft (2.3 m)	lb (kg)								16' 1" (4.91 m)
5 ft (1.5 m)	lb (kg)								16' 6" (5.04 m)
2.5 ft (0.8 m)	lb (kg)								16' 5" (5.02 m)
G. L.	lb (kg)								15' 11" (4.86 m)
-2.5 ft (-0.8 m)	lb (kg)								14' 11" (4.54 m)
-5 ft (-1.5 m)	lb (kg)								13' 1" (4.00 m)
-10 ft (-3.0 m)	lb (kg)								10' 2" (3.09 m)

SK45SR Canopy	Standard Arm: 5' 1" (1.55 m) Without bucket		Shoe: 15.7" (400 mm)		Add-on Counterweight		At Max. Reach		Radius
	5' (1.5 m)	7.5' (2.3 m)	10' (3.0 m)	12.5' (3.8 m)	15' (4.6 m)				
15 ft (4.6 m)	lb (kg)								10' 10" (3.31 m)
12.5 ft (3.8 m)	lb (kg)								13' 6" (4.13 m)
10 ft (3.0 m)	lb (kg)								15' 2" (4.62 m)
7.5 ft (2.3 m)	lb (kg)								16' 1" (4.91 m)
5 ft (1.5 m)	lb (kg)								16' 6" (5.04 m)
2.5 ft (0.8 m)	lb (kg)								16' 5" (5.02 m)
G. L.	lb (kg)								15' 11" (4.86 m)
-2.5 ft (-0.8 m)	lb (kg)								14' 11" (4.54 m)
-5 ft (-1.5 m)	lb (kg)								13' 1" (4.00 m)
-10 ft (-3.0 m)	lb (kg)								10' 2" (3.09 m)

### Note about lifting chart

- Do not attempt to lift or hold any load that is greater than these lifting capacities at their specified lift point radius and heights. Weight of all accessories must be deducted from the above lifting capacities.
- Lifting capacities are based on machine standing on level, firm, and uniform ground. User must make allowance for job conditions such as soft or uneven ground, out of level conditions, side loads, sudden stopping of loads, hazardous conditions, experience of personnel, etc.
- Arm bucket pin, without bucket is defined as lift point.
- The above lifting capacities are in compliance with SAE J10567. They do not exceed 87 % of hydraulic lifting capacity or 75 % of tipping load. Lifting capacities marked with an asterisk (\*) are limited by hydraulic capacity rather than tipping load.
- Operator should be fully acquainted with the Operator's and Maintenance Instructions before operating this machine. Rules for safe operation of equipment should be adhered to at all times.
- Lifting capacities apply to only machines as originally manufactured and normally equipped by KOBELCO CONSTRUCTION MACHINERY CO., LTD.

