

Lifting Capacities

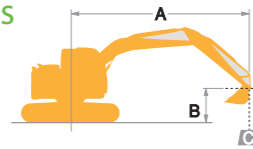

Rating over front

Rating over side or 360 degrees

A – Reach from swing centerline for bucket hook
 B – Bucket hook height above/below ground
 C – Lifting capacities in pounds (kilogram)
 Relief valve setting: 4,970 psi (34.3 MPa)

ED160 Blade Runner		Arm: 7' 10" (2.38 m) Bucket: 0.65 cu yd (0.50 m³) SAE heaped 840 lbs (380 kg) Shoe: 23.6" (600 mm) Blade: Front side and Blade up										
		4' 11" (1.5 m)		9' 10" (3.0 m)		14' 9" (4.5 m)		19' 8" (6.0 m)		At Max. Reach		Radius
B	A	Rating over front	Rating over side or 360 degrees	Rating over front	Rating over side or 360 degrees	Rating over front	Rating over side or 360 degrees	Rating over front	Rating over side or 360 degrees	Rating over front	Rating over side or 360 degrees	
24' 7" (7.5 m)	lb (kg)									*3,360 (1,520)	*3,360 (1,520)	13' 8" (4.17 m)
19' 8" (6.0 m)	lb (kg)					*6,580 (2,980)	*6,580 (2,980)			*2,790 (1,260)	*2,790 (1,260)	18' 11" (5.77 m)
14' 9" (4.5 m)	lb (kg)					*7,330 (3,320)	*7,330 (3,320)	5,100 (2,310)	4,330 (2,010)	*2,660 (1,210)	*2,660 (1,210)	21' 10" (6.65 m)
9' 10" (3.0 m)	lb (kg)			*13,300 (6,030)	*13,300 (6,030)	8,100 (3,670)	6,850 (3,110)	4,880 (2,210)	4,220 (1,910)	*2,750 (1,250)	*2,750 (1,250)	23' 4" (7.11 m)
4' 11" (1.5 m)	lb (kg)			14,930 (6,770)	11,550 (5,240)	7,420 (3,360)	6,240 (2,830)	4,600 (2,080)	3,960 (1,790)	*3,040 (1,380)	2,870 (1,300)	23' 8" (7.23 m)
G.L.	lb (kg)			14,170 (6,420)	10,920 (4,950)	6,970 (3,160)	5,830 (2,640)	4,380 (1,980)	3,760 (1,700)	3,390 (1,530)	2,930 (1,330)	23' 0" (7.02 m)
-4' 11" (-1.5 m)	lb (kg)	*12,280 (5,570)	*12,280 (5,570)	14,130 (6,410)	10,890 (4,940)	6,820 (3,090)	5,690 (2,580)	4,310 (1,950)	3,690 (1,670)	3,860 (1,750)	3,330 (1,510)	21' 2" (6.45 m)
-9' 10" (-3.0 m)	lb (kg)	*18,720 (8,490)	*18,720 (8,490)	*14,010 (6,350)	11,170 (5,070)	6,950 (3,150)	5,810 (2,630)			5,220 (2,370)	4,460 (2,020)	17' 8" (5.40 m)

ED160 Blade Runner		Arm: 9' 4" (2.84 m) Bucket: 0.5 cu yd (0.38 m³) SAE heaped 750 lbs (340 kg) Shoe: 23.6" (600 mm) Blade: Front side and Blade up												
		4' 11" (1.5 m)		9' 10" (3.0 m)		14' 9" (4.5 m)		19' 8" (6.0 m)		24' 7" (7.5 m)		Radius		
B	A	Rating over front	Rating over side or 360 degrees	Rating over front	Rating over side or 360 degrees	Rating over front	Rating over side or 360 degrees	Rating over front	Rating over side or 360 degrees	Rating over front	Rating over side or 360 degrees			
24' 7" (7.5 m)	lb (kg)					*3,980 (1,800)	*3,980 (1,800)					*3,200 (1,450)	*3,200 (1,450)	15' 7" (4.77 m)
19' 8" (6.0 m)	lb (kg)					*5,610 (2,540)	*5,610 (2,540)	*3,470 (1,570)	*3,470 (1,570)			*2,670 (1,210)	*2,670 (1,210)	20' 6" (6.26 m)
14' 9" (4.5 m)	lb (kg)					*6,290 (2,850)	*6,290 (2,850)	4,930 (2,230)	4,280 (1,940)			*2,520 (1,140)	*2,520 (1,140)	23' 4" (7.11 m)
9' 10" (3.0 m)	lb (kg)			*10,930 (4,950)	*10,930 (4,950)	7,900 (3,580)	6,700 (3,030)	4,670 (2,110)	4,040 (1,830)			*2,560 (1,160)	*2,560 (1,160)	24' 9" (7.56 m)
4' 11" (1.5 m)	lb (kg)			14,640 (6,640)	11,390 (5,160)	7,150 (3,240)	6,010 (2,720)	4,340 (1,960)	3,740 (1,690)	2,850 (1,290)	2,460 (1,110)	*2,780 (1,260)	2,430 (1,100)	25' 2" (7.68 m)
G.L.	lb (kg)			13,430 (6,090)	10,370 (4,700)	6,580 (2,980)	5,500 (2,490)	4,070 (1,840)	3,480 (1,570)			2,850 (1,290)	2,450 (1,110)	24' 6" (7.48 m)
-4' 11" (-1.5 m)	lb (kg)	*10,610 (4,810)	*10,610 (4,810)	13,160 (5,960)	10,150 (4,600)	6,340 (2,870)	5,280 (2,390)	3,940 (1,780)	3,360 (1,520)			3,200 (1,450)	2,750 (1,240)	22' 9" (6.94 m)
-9' 10" (-3.0 m)	lb (kg)	*16,440 (7,450)	*16,440 (7,450)	13,380 (6,060)	10,330 (4,680)	6,380 (2,890)	5,320 (2,410)					4,190 (1,900)	3,570 (1,610)	19' 6" (5.95 m)
-14' 9" (-4.5 m)	lb (kg)			*8,890 (4,030)	*8,890 (4,030)							*5,950 (2,690)	*5,950 (2,690)	13' 10" (4.22 m)

- Do not attempt to lift or hold any load that is greater than these lift capacities at their specified lift point radius and heights. Weight of all accessories must be deducted from the above lift capacities.
- Lift capacities are based on machine standing on level, firm, and uniform ground. User must make allowance for job conditions such as soft or uneven ground, out of level conditions, side loads, sudden stopping of loads, hazardous conditions, experience of personnel, etc.
- Bucket lift hook is defined as lift point.
- The above lifting capacities are in compliance with SAE J/ISO 10567. They do not exceed 87 % of hydraulic lifting capacity or 75 % of tipping load. Lifting capacities marked with an asterisk (*) are limited by hydraulic capacity rather than tipping load.
- Operator should be fully acquainted with the Operator's and Maintenance Instructions before operating this machine. Rules for safe operation of equipment should be adhered to at all times.
- Lift capacities apply to only machines as originally manufactured and normally equipped by KOBELCO CONSTRUCTION MACHINERY CO., LTD.

Standard Equipment

ENGINE

Engine, MITSUBISHI D04EG-TAA, Diesel engine with turbocharger and intercooler, Tier 4 interim certified

- Automatic engine deceleration
- Batteries (2 x 12V - 80 Ah)
- Starting motor (24 V - 5kW), 50 amp alternator
- Automatic engine low idle for low engine oil pressure
- Engine oil pan drain cock
- Double element air cleaner

CONTROL

Working mode selector (H-mode, S-mode and ECO-mode)

SWING SYSTEM & TRAVEL SYSTEM

- Swing rebound prevention system
- Straight propel system
- Two-speed travel with automatic down shift
- Sealed & lubricated track links
- 2' 0" (600 mm) track shoes
- Grease-type track adjusters
- Automatic swing brake

DOZER BLADE

Tilt & angle

CAB & CONTROL

- Two control levers, pilot-operated
- Horn, electric
- Integrated left-right slide-type control box
- Cab light (interior)
- Coat hook
- Large cup holder
- Detachable two-piece floor mat
- 7-way adjustable suspension seat
- Retractable seatbelt
- Headrest
- Handrails
- Heater and defroster
- Intermittent windshield wiper with double-spray washer
- Skylight
- Top guard
- Tinted safety glass
- Pull-type front window and removable lower front window
- Easy-to-read multi-display monitor
- Automatic air conditioner
- Emergency escape hammer

Radio, AM/FM Stereo with speakers

- Travel alarm
- Drain pressure switch
- DPF regeneration switch
- 12V converter
- KOMEX
- Three rear view mirrors

Optional Equipment

- Boom & arm holding valve
- Front-guard protective structures (May interfere with bucket action)
- Additional hydraulic circuit
- Control pattern changer (2-way)
- Cab additional light
- Rain visor (may interfere with bucket action)
- Three front working lights
- Vandalism guards
- Delete dozer blade

Note: Standard and optional equipment may vary. Consult our KOBELCO dealer for specifics.

Note: This catalog may contain attachments and optional equipment that are not available in your area. It may also contain photographs of machines with specifications that differ from those of machines sold in your area. Please consult your nearest KOBELCO distributor for those items you require.

Due to our policy of continuous product improvements all designs and specifications are subject to change without advance notice.

Copyright by KOBELCO CONSTRUCTION MACHINERY CO., LTD. No part of this catalog may be reproduced in any manner without notice.

KOBELCO CONSTRUCTION MACHINERY U.S.A. INC.

22350 Merchants Way Katy, TX 77449
<http://www.KOBELCO-USA.com/>

Inquiries To:

Hydraulic Excavators

ED160 Blade Runner

Bucket Capacity :
 0.65 cu yd (0.50 m³) SAE heaped

Engine Power :
 92.8 hp (69.2 kW) / 2,000 rpm (SAE NET)

Operating Weight :
 35,200 lb (15,900 kg)



Complies with the latest exhaust emission regulations



US EPA
Interim Tier IV



EU (NRMM)
Stage III B



Japanese
Regulations

ED160 Blade Runner

Dual Purpose from the Start!

Productive Digging and Large-Capacity Dozing

Fit a hydraulic excavator with a large, tilt-angle dozer blade for great performance both digging and dozing—that's the ED160 Blade Runner. Using one machine to cover a whole range of jobs including leveling, digging, pipe laying and backfilling, gives a massive boost in productivity. The tilt-angle blade allows leveling and backfilling on irregular ground. And the ED160 Blade Runner features the short rear swing SR spec that means the operator can get on with the job in the tightest spaces without worrying about what's behind. The ED160 Blade Runner has built-in strength to deal with the double tasks of dozing and digging. Its iNDr noise and dust control system cuts engine noise and simplifies maintenance. Add to that a well-equipped, comfortable cab. Giving fast, efficient digging and large capacity dozing, this one machine is versatility itself on site.



Pursuing the "Three E's"
The Perfection of Next-Generation,
Network Performance

Enhancement
Greater Performance Capacity

Economy
Improved Cost Efficiency

Environment
Features That Go Easy on the Earth

The Revolutionary Integrated Noise and Dust Reduction Cooling System

iNDr

KOBELCO's exclusive iNDr Cooling System delivers amazingly quiet operation.

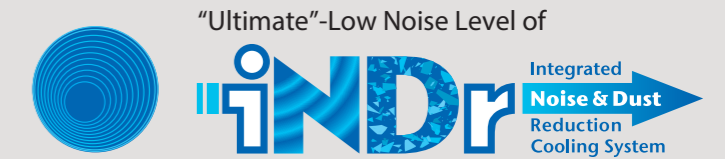

"Ultimate Low Noise" Design Minimizes Sound Leakage

KOBELCO's unique iNDr system achieves exceptional results preventing engine and cooling fan noise escaping the engine compartment. This "Ultimate Low Noise" machine cuts noise to 75 dB (A) at 1.5 m, far surpassing legal requirements.

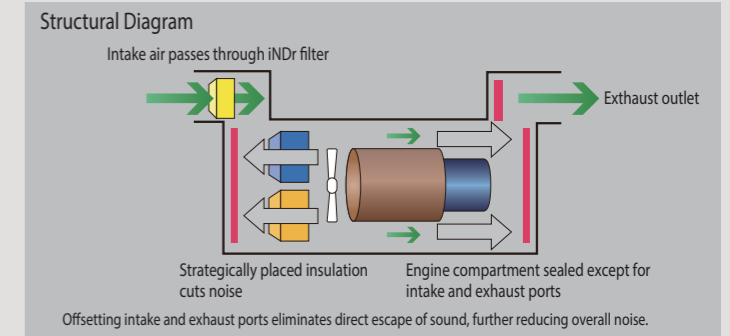

Eliminating Dust Optimizes Cooling Performance

The high-density 60-mesh filter* removes dust from the air intake, which prevents clogging of the cooling system and air cleaner, and maintains the engine at peak performance. Its wave form concentrates dust in the grooves, keeping a clear passage for a smooth flow of air.

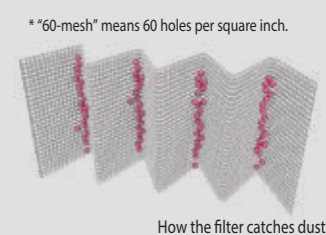

ED160 Blade Runner

Efficient Performance

Large Capacity Dozing

ED160 Blade Runner is fitted with a large dozing blade 10' 8" (3,260 mm) wide and 2' 8" (815 mm) high, and can readily shift large volumes of earth, working to a height of 2' 7" (790 mm) and a depth of 24" (600 mm). With 32,600 lbf (145 kN) of drawbar pulling force, the ED160 has the power to doze and backfill in all recommended operating positions.

Dimensions:

10' 8" (3,260 mm) (width) x 2' 8" (815 mm) (height)

Working Ranges:

2' 7" (790 mm) (height), 24" (600 mm) (depth)

Drawbar Pulling Force: 44,063 lbf (196 kN)

Dozer Capacity: 2.1 cu yd (1.6 m³)



Power, Angle and Tilt Capability (PAT)

The 6-way dozer blade has Power, Angle and Tilt capability (PAT) operated from the cab. With a single control lever, the blade can be angled



25 degrees to the left or right for dispensing earth and materials away for the operator's path. The blade also tilts up on the left and right sides by 1' 6" (455 mm) for slope grading, culverts and ditches.



6-way Dozing Capability

In addition to powerful digging and fine capability, the new ED160 Blade Runner offers a standard 6-way dozer blade and foldable, lockable blade wings that the clearing path beyond the width of tracks.

Single Dozer Lever

A conveniently located single dozer lever controls all blade hydraulic function.

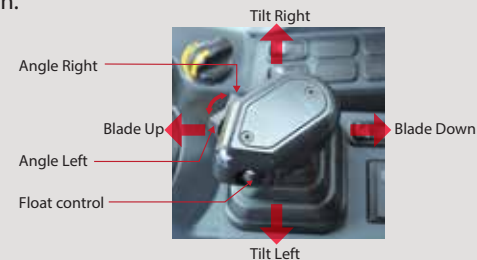

Exclusive Dozer Circuit

The dedicated dozer circuit has a relief valve setting of 3,970 psi (27.4 MPa). Steady and powerful dozing is unaffected by digging, swinging, travel or other machine function.

Curved Track Shoes

The curved shape of the crawler shoes improves maneuverability with good grip and gives crisp travel minimizing damage to ground surfaces.



Plenty of Ground Clearance

Excellent ground clearance ensures unhindered travel.



Ground Clearance: 1' 8" (455 mm)

Top-Class Powerful Digging

For More Efficient Performance

Max. Bucket Digging Force:

20,300 lbf {90.1 kN} (ISO 6015)

19,700 lbf {87.8 kN} (SAE J 1179)

Max. Arm Crowding Force:

14,500 lbf {64.4 kN} (ISO 6015)

14,000 lbf {62.3 kN} (SAE J 1179)

Great Swing Power, Short Cycle Times

Powerful swing power and top-class swing speed.

Swing Speed: 11.0 min⁻¹ {rpm}

Swing Torque: 29,400 lb-ft {39.9 kN}

Optional N&B (Crusher and Breaker)

The operator selects the desired mode from inside the cab, and the selector valve automatically configures the machine accordingly.

Seamless, Smooth Combined Operations

The machines have inherited the various systems that make inching and combined operations easy and accurate, with further refinements that make a good thing even better. Leveling and other combined operations can be carried out with graceful ease.

- Electronic active control system
- Arm regeneration system
- Boom lowering regeneration system
- Swing priority system
- Swing rebound prevention system

Easy Transportation

Dozer wings fold back to reduce blade width from 10' 8" (3,260 mm) to 8' 1" (2,460 mm). With a track width of 8' 6" (2,590 mm) and weight of 35,200 lbs (15,900 kg), drive the ED160 onto a tag-a-long trailer and you're off to the job site.



Compact Swing Radius

Compact design ensures efficient operation on sites where space is limited.



Tail overhang: 7.7" {195 mm}



ED160 Blade Runner

More Work with Less Fuel!

Interim Tier 4 Compliant Engine (No Exhaust Fluid Required)

PM emissions cut:

Limits creation of particulate matter (which results from incomplete combustion of fuel)

Common rail system

High-pressure injection atomizes the fuel, and injection timing is more precise, improving combustion efficiency.

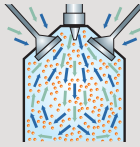

Diesel Particulate Filter (DPF)

Carbon is built up as soot on the diesel particulate filter and is burned off at high temperature. No Exhaust fluid required.

The system allows manual or automatic filter regeneration.

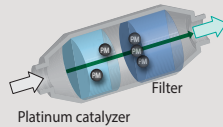

NOx emissions cut:

Reduces nitrogen oxides (created by reaction with oxygen at high temperature)

EGR cooler

While ensuring sufficient oxygen for combustion, cooled exhaust gases are mixed with the air intake and re-circulated into the engine. This reduces the combustion temperatures and reduces formation of Nitrogen Oxides.

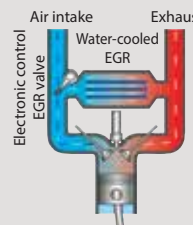

ECO-mode



Work modes for a closer match to the job at hand. An addition to the existing H-mode and S-mode, the new ECO-mode saves even more energy.

H-mode:

For heavy duty operation, when a higher performance level is required.

S-mode:

For normal operations with lower fuel consumption.

ECO-mode:

Puts priority on low fuel consumption and economic performance.

Significant Extension of Continuous Working Hours

The combination of a large-capacity fuel tank and excellent fuel efficiency delivers an impressive increase in the length of continuous usage.



Fuel tank capacity:
52.8 US gal
(200 L)

Automatic Acceleration / Deceleration Function Reduces Engine Speed

Engine speed is automatically reduced when the control lever is placed in neutral, effectively saving fuel and reducing noise and exhaust emissions.

The engine proportionally returns to the previous speed when the lever is moved out of neutral.

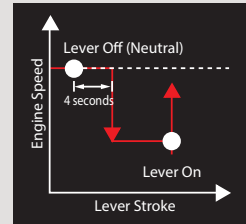

Attachment Mode Selector Switch

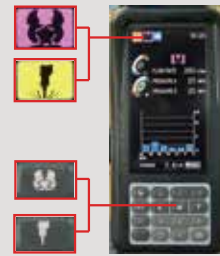

There is a choice of three different attachment modes, to accommodate bucket, crusher, or breaker. The desired attachment mode can be selected with a switch, which automatically configures the selector valve. All attachment modes can be used in S-mode, H-mode or ECO-mode.

NEXT-3E Technology

New Hydraulic System

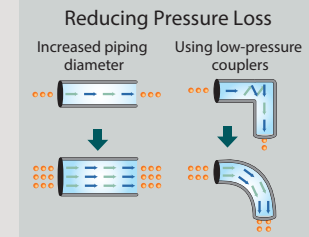

Rigorous inspections for pressure loss are performed on all components of the hydraulic piping, from the spool of control valve to the connectors. This regimen, combine with the use of a new, high-efficiency pump, cuts energy loss to a minimum.

NEXT-3E Technology

Total Tuning Through Advanced ITCS Control

The next-generation engine control is governed by a new version of ITCS, which responds quickly to sudden changes in hydraulic load to ensure that the engine runs as efficiently as possible with a minimum of wasted output.



ITCS (Intelligent Total Control System) is an advanced, computerized system that provides comprehensive control of all machine functions.

NEXT-3E Technology

Next-Generation Electronic Engine Control



The high-pressure, common-rail fuel-injection engine with the multiple injection system features adjust table control to maximize fuel efficiency and provide powerful low-speed torque. The result is a highly fuel-efficient engine.



ED160 Blade Runner

Cab Design That Puts the Operator First

Big Cab

The big cab provides a roomy operating space with plenty of legroom, and the door opens wide for entry and exit. As well as giving a wide, open view to the front, the cab has increased window areas on both sides and to the rear, for improved visibility in all directions.

Excellent Visibility

Taking out the right-side cab support to make a single window has improved visibility to the right.



Wide-Access Cab Aids Smooth Entry and Exit

Easy entry and exit assured with wider cab entry and safety lock lever integrated with mounting for control levers.



Comfortable Operating Environment



• One-touch lock release simplifies opening and Powerful automatic air conditioner closing front window



• Two-speaker FM/AM radio with station select • Spacious luggage tray



• Large cup holder • Dozer control lever

KOMEX (Excavator Remote Monitoring System)

Total Support for Machines with Network Speed and Accuracy

Our "KOMEX" allows you to use the Internet to manage information from your office for machines operating in all areas. Be prepared for any problems with strategic information and cost management. This provides a wide range of support for your business operations.

Direct Access to Operational Status

- Location Data
- Operating Hours
- Fuel Consumption Data
- Graph of Work Content
- Graph of Machine Duty Cycles

Maintenance Data and Warning Alerts

- Machine Maintenance Data

Security System

- Engine Start Alarm
- Area Alarm



ROPS Cab

The newly developed, ROPS (Roll-Over-Protective Structure)-compliant cab clears ISO standards (ISO-12117-2: 2008) and ensures greater safety for the operator.



- Level 2 FOPS Guard (ISO 10262) is equipped as standard.
- To fit vandalism guards, please contact your KOBELCO dealer. (Mounting brackets for vandalism guards provided standard)

Multi-Display Color Monitor for Easy Checking



An LCD multi-display color monitor is fitted as standard. Operations data as well as the full range of machine status data can readily be checked.

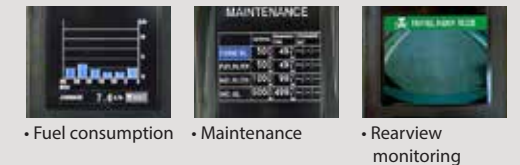

- Fuel consumption
- Maintenance
- Rearview monitoring

Safety Features



- Thermal guard prevents contact with hot components during engine inspections
- Retractable seatbelt requires no manual adjustment



- Hammer for emergency exit
- Travel alarm



- Swing flashers
- Rear view camera

ED160 Blade Runner

Fast, Accurate and Low-Cost Maintenance

Comfortable "On the Ground" Maintenance

Most daily inspection and regular maintenance tasks can be easily implemented with ready access on the ground.

- Easy access to cooling units (Left side)
- Easy access to engine (Center)



Air cleaner Radiator reservoir tank



• Easy access to main control valves (Front)

- Easy access to pump & filters (Right side)

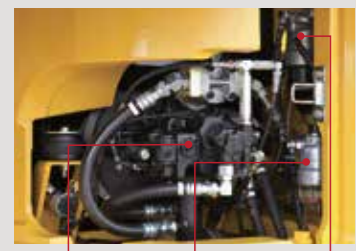

Hydraulic pump Fuel pre-filter Fuel Filter



• Independent Dozer control pump is provided.

Fast Maintenance



• Engine quick drain cock can be turned without tools.



• Hour meter can be checked while standing on the ground



• Easy-access fuse box. More finely differentiated fuses make it easier to locate malfunctions.



• Washer fluid tank located under the cab floor mat.

Easy Cleaning



• Detachable two-piece floor mat with handles for easy removal. A floor drain located under floor mat is easily removed without tools for cleaning



• Internal and external air conditioner filters can be easily removed without tools for cleaning



• Special crawler frame designed is easily cleaned of mud

iNDr Filter: Visual Checking and Easy Cleaning

When checking and cleaning the cooling system, one must deal with several different components like the radiator, oil cooler and intercooler, which all must be handled in different ways. But with the iNDr filter, there's just one filter in one place. If it looks dirty during start-up inspection, it can be cleaned easily and quickly.



Monitor Display with Essential Information for Accurate Maintenance Checks

Displays only the maintenance information that's needed, when it's needed.

Self-diagnostic function that provides early-warning detection and display of electrical system malfunctions.

Record function of previous technical issues including irregular and transient malfunction.



Reliable Construction

Attachment

The attachment has been reinforced to handle a higher work volume, with greater power and excellent durability that can withstand demanding work conditions.

Understructure

Over size travel motors and heavy duty undercarriage enhance durability.

Heavy-duty idlers, lower rollers and carrier rollers are all lifetime lubricated for dependability and a long trouble-free working life.



Specifications

PERFORMANCE		
MODEL	ED160 Blade Runner-3	
Bucket Capacity	SAE heaped	cu yd (m ³)
	Struck	cu yd (m ³)
Swing Speed	min ⁻¹ (rpm)	
Swing Torque	lb-ft (kN)	
Travel Speed	mph (km/h)	
Gradeability	% (degree)	
Bucket Digging Force	lbf (kN)	
Arm Crowding Force	lbf (kN)	
Drawbar Pulling Force	lbf (kN)	
WEIGHT		
Operating Weight	lbs (kg)	
Ground Pressure	psi (kPa)	
Shoe Width	ft-in (mm)	
ENGINE		
Model	MITSUBISHI D04EG-TAA	
Type	Direct injection, water-cooled, 4-cycle, 4-cylinder, turbocharged diesel engine, intercooler, Tier 4 interim certified	
Rated Power Output	(SAE NET)	HP (kW)
	(without fan)	HP (kW)
Max. Torque	(SAE NET)	lb-ft (N-m/min ⁻¹)
	(without fan)	lb-ft (N-m/min ⁻¹)
Displacement	cu in (L)	
HYDRAULIC SYSTEM		
Pump	Two variable displacement pumps + two gear pumps	
Max. Discharge Flow	US gph (L/min)	2 x 34.3 (130), 5.3 (20), 14.5 (55)
Relief Valve Setting (main)	psi (MPa)	4,970 (34.3)
Swing Motor	Axial piston motor	
Travel Motor	2 x axial piston, two-step motor	
DOZER BLADE		
Dozer Capacity	cu yd (m ³)	
Width x Height	ft-in (mm)	
Working Ranges (height/depth)	ft-in (mm)	
Max. Tilt Height	ft-in (mm)	
Angle	degree	
REFILLING CAPACITIES & LUBRICATION		
Fuel Tank	US gal (L)	52.8 (200)
Cooling System	US gal (L)	3.7 (14)
Engine Oil	US gal (L)	4.9 (18.5)
Travel Reduction Gear	US gal (L)	2 x 0.6 (2.1)
Swing Reduction Gear	US gal (L)	0.4 (1.65)
Hydraulic oil tank (System)	US gal (L)	22.5 (85.2) (33.5 (126.7))

Dimensions

Arm length	Unit: ft-in (mm)	
	7' 10" (2.38 m)	9' 4" (2.84 m)
A Overall length	28' 0" (8,530)	28' 3" (8,620)
B Overall height (to top of boom)	8' 10" (2,700)	10' 3" (3,130)
C Overall width of crawler	8' 6" (2,590)	
D Overall height (to top of cab)	9' 11" (3,030)	
E Ground clearance of rear end*	3' 4" (1,010)	
F Ground clearance*	1' 8" (455)	
G Tail swing radius	4' 11" (1,490)	
H Tumbler distance	9' 2" (2,800)	
I Overall length of crawler	11' 10" (3,600)	
J Track gauge	6' 6" (1,990)	
K Shoe width	2' 0" (600)	
L Overall width of upperstructure	8' 2" (2,490)	
M Overall width	10' 8" (3,260)	
N Folding blade width	8' 1" (2,460)	

* without including height of shoe lug.

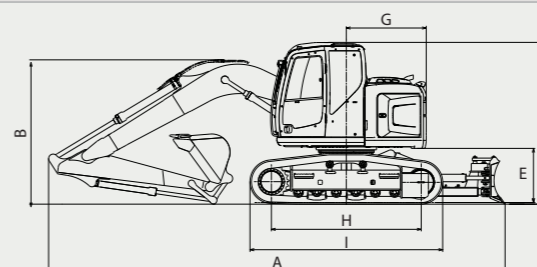

Working Ranges

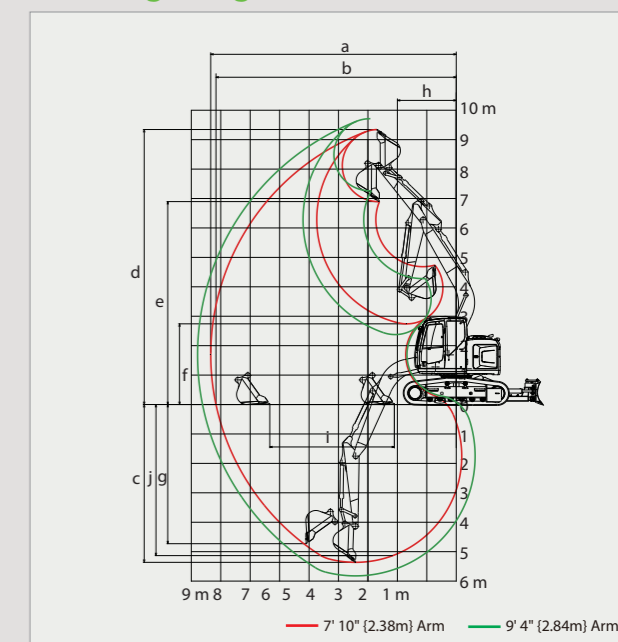

Boom	Unit: ft-in (m)	
	7' 10" (2.38m)	9' 4" (2.84m)
Arm	15' 4" (4.68m)	15' 4" (4.68m)
a - Max. digging reach	27' 4" (8.34)	28' 10" (8.78)
b - Max. digging reach at ground level	26' 9" (8.16)	28' 3" (8.61)
c - Max. digging depth	17' 7" (5.36)	19' 1" (5.82)
d - Max. digging height	30' 8" (9.34)	31' 10" (9.71)
e - Max. dumping clearance	22' 8" (6.90)	23' 10" (7.26)
f - Min. dumping clearance	9' 0" (2.74)	7' 10" (2.38)
g - Max. vertical wall digging depth	15' 6" (4.73)	17' 4" (5.29)
h - Min. swing radius	6' 7" (2.00)	7' 10" (2.40)
i - Horizontal digging stroke at ground level	13' 11" (4.23)	15' 6" (4.72)
j - Digging depth for 8 feet flat bottom	16' 10" (5.13)	18' 6" (5.63)
Bucket capacity SAE heaped cu yd (m ³)	0.65 (0.50)	0.50 (0.38)

Bucket Selection Chart

Bucket Duty	Capacity (SAE) cu yd (m ³)	Width in (m)	Bucket Weight lb (kg)	Arm 9' 4" (2.84 m)
General	0.30 (0.229)	18 (0.457)	650 (296)	H
	0.44 (0.336)	24 (0.609)	720 (327)	H
	0.58 (0.443)	30 (0.762)	835 (379)	M
	0.73 (0.558)	36 (0.914)	905 (411)	L
Heavy Duty	0.88 (0.672)	42 (1.066)	1,015 (460)	L
	0.30 (0.229)	18 (0.457)	705 (320)	H
	0.44 (0.336)	24 (0.609)	780 (354)	H
	0.58 (0.443)	30 (0.762)	900 (408)	M
	0.73 (0.558)	36 (0.914)	975 (442)	L
	0.88 (0.672)	42 (1.066)	1,090 (494)	X

H: Used with material weight up to 3,000 lb/cu yd (1,780 kg/m³)

M: Used with material weight up to 2,500 lb/cu yd (1,483 kg/m³)

L: Used with material weight up to 2,000 lb/cu yd (1,186 kg/m³)

X: Not recommended

