

### ■ Main Specifications

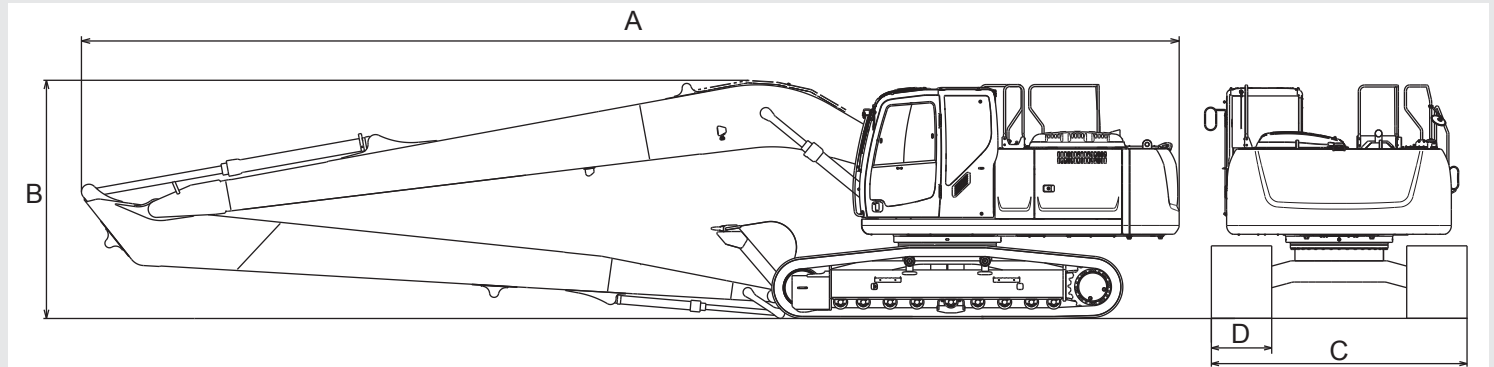

Model		SK210LC-9 LR	SK260LC-9 LR
Long reach attachment		50ft	60ft
Engine		HINO J05E-TI	HINO J05E-TI
Rated power output (SAE NET)	hp{kW} / rpm	157 {117} / 2,000	176{131} / 2,100
Swing speed	rpm	12.5	10.2
Operating weight	lbs {kg}	52,000 {23,600}	60,400 {27,400}
Ground pressure	psi {kPa}	5.4 {37}	6.0 {41}
A. Overall length	ft-in {mm}	41'6" {12,640}	47'8" {14,520}
B. Overall height	ft-in {mm}	10'2" {3,100}	10'4" {3,150}
C. Overall width	ft-in {mm}	10'5" {3,180}	11'1" {3,390}
D. Shoe width	ft-in {mm}	31.5" {800}	31.5" {800}

### ■ Working Ranges

Unit: ft-in

	SK210LC-9 LR	SK260LC-9 LR
	50ft	60ft
Boom	28'8"	33'11"
Range	20'10"	27'1"
a- Max. digging reach	51'11"	60'10"
b- Max. digging reach at ground level	51'7"	60'6"
c - Max. digging depth	39'5"	48'4"
d- Max. digging height	45'7"	47'10"
e- Max. dumping clearance	37'10"	40'5"
f - Min. dumping clearance	6'10"	5'2"
g- Max. vertical wall digging depth	36'8"	40'5"
h- Min. swing radius	15'6"	18'4"
i - Horizontal digging stroke at ground level	38'1"	48'5"
j - Digging depth for 2.4 m (8') flat bottom	39'1"	47'10"
Bucket capacity SAE heaped cu.yd.	0.6	0.5

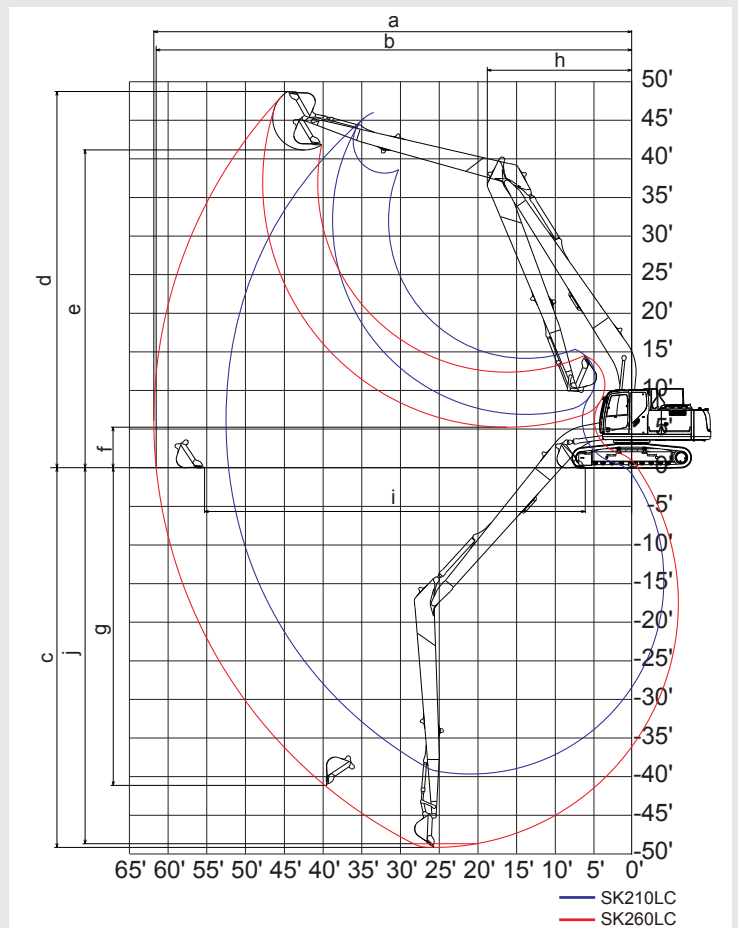

# LONG REACH ATTACHMENT

**SK210<sub>LC</sub>**  
SK210LC-9

**SK260<sub>LC</sub>**  
SK260LC-9

## Lifting Capacities

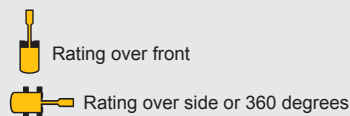
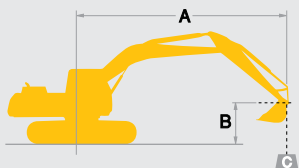

A – Reach from swing centerline for bucket hook  
B – Bucket hook height above/below ground  
C – Lifting capacities in pounds

**SK210LC 50ft** Boom; 28'8", Arm; 20'10", Bucket; 06cu.yd. SAE heaped 820 lbs, Counterweight; 12,800 lbs, Shoe; 31.5"

B	A	5'		10'		15'		20'		25'		30'		35'		40'		45'		At Max. Reach		Radius											
		Rating over front	Rating over side or 360 degrees	Rating over front	Rating over side or 360 degrees	Rating over front	Rating over side or 360 degrees	Rating over front	Rating over side or 360 degrees	Rating over front	Rating over side or 360 degrees	Rating over front	Rating over side or 360 degrees	Rating over front	Rating over side or 360 degrees	Rating over front	Rating over side or 360 degrees	Rating over front	Rating over side or 360 degrees	Rating over front	Rating over side or 360 degrees												
40'	lb																					* 1,630	* 1,630	33'10"									
35'	lb														* 3,000	* 3,000							* 1,460	* 1,460	38'3"								
30'	lb														* 3,860	* 3,860	* 2,350	* 2,350					* 1,360	* 1,360	41'7"								
25'	lb														* 4,440	* 4,440	* 3,420	* 3,420					* 1,320	* 1,320	44'2"								
20'	lb														* 4,830	* 4,830	* 4,180	3,910	* 2,060	* 2,060			* 1,320	* 1,320	46'0"								
15'	lb												* 5,750	* 5,750	* 5,220	4,930	* 4,830	3,740	* 2,940	2,820			* 1,350	* 1,350	47'2"								
10'	lb														* 6,440	6,090	* 5,660	4,610	* 5,110	3,530	* 3,570	2,700	* 1,420	* 1,420	47'11"								
5'	lb														* 5,270	* 5,270	* 16,000	15,510	* 11,170	10,380	* 8,650	7,470	* 7,130	5,600	* 6,120	4,290	* 5,410	3,320	* 4,010	2,560	* 1,530	* 1,530	48'0"
GL	lb														* 5,010	* 5,010	* 12,620	* 12,620	* 12,550	9,330	* 9,560	6,810	* 7,740	5,160	* 6,530	3,990	5,450	3,120	* 4,180	2,440	* 1,680	* 1,680	47'8"
-5'	lb	* 4,390	* 4,390	* 6,370	* 6,370	* 11,700	* 11,700	* 13,380	8,650	* 10,200	6,320	* 8,200	4,810	6,530	3,750	5,280	2,960	* 3,840	2,350	* 1,900	* 1,900			* 1,900	* 1,900	46'9"							
-10'	lb	* 6,280	* 6,280	* 8,190	* 8,190	* 12,750	12,660	* 13,670	8,290	10,460	6,010	7,990	4,580	6,350	3,580	5,170	2,850	* 2,560	2,300	* 2,210	* 2,210			* 2,210	* 2,210	45'3"							
-15'	lb	* 8,250	* 8,250	* 10,300	* 10,300	* 14,760	12,660	* 13,460	8,170	10,310	5,870	7,870	4,460	6,260	3,500	5,130	2,810							* 2,670	2,500	43'1"							
-20'	lb	* 10,360	* 10,360	* 12,730	* 12,730	* 16,890	12,870	* 12,750	8,230	* 10,030	5,870	7,860	4,460	6,280	3,510	* 3,860	2,880							* 3,370	2,860	40'3"							
-25'	lb	* 12,690	* 12,690	* 15,590	* 15,590	* 14,920	13,270	* 11,470	8,450	* 9,080	6,020	* 7,270	4,580	* 5,690	3,660									* 4,580	3,470	36'6"							
-30'	lb			* 16,130	* 16,130	* 12,030	* 12,030	* 9,410	8,850	* 7,410	6,330	* 5,640	4,880											* 5,900	4,580	31'6"							
-35'	lb					* 7,700	* 7,700	* 6,020	* 6,020															* 4,460	* 4,460	24'5"							

**SK260LC 60ft** Boom; 33'11", Arm; 27'1", Bucket; 05cu.yd. SAE heaped 770 lbs, Counterweight; 15,400 lbs, Shoe; 31.5"

B	A	5'		10'		15'		20'		25'		30'		35'		40'		45'		50'		55'		At Max. Reach		Radius			
		Rating over front	Rating over side or 360 degrees	Rating over front	Rating over side or 360 degrees	Rating over front	Rating over side or 360 degrees	Rating over front	Rating over side or 360 degrees	Rating over front	Rating over side or 360 degrees	Rating over front	Rating over side or 360 degrees	Rating over front	Rating over side or 360 degrees	Rating over front	Rating over side or 360 degrees	Rating over front	Rating over side or 360 degrees	Rating over front	Rating over side or 360 degrees	Rating over front	Rating over side or 360 degrees	Rating over front	Rating over side or 360 degrees				
40'	lb																								* 1,370	* 1,370	45'8"		
35'	lb																									* 1,320	* 1,320	49'0"	
30'	lb																									* 1,300	* 1,300	51'7"	
25'	lb																									* 1,310	* 1,310	53'8"	
20'	lb																										* 1,350	* 1,350	55'2"
15'	lb																										* 1,420	* 1,420	56'3"
10'	lb																										* 1,520	* 1,520	56'9"
5'	lb																										* 1,650	* 1,650	56'11"
GL	lb	* 3,070	* 3,070	* 5,660	* 5,660	* 12,570	* 12,570	* 11,850	* 11,850	* 8,900	* 8,900	* 7,130	6,920	* 5,980	5,430	* 5,170	4,320	4,590	3,450	4,160	2,760	* 2,840	2,190	* 1,820	* 1,820	56'7"			
-5'	lb	* 4,450	* 4,450	* 6,270	* 6,270	* 10,720	* 10,720	* 13,180	11,030	* 9,880	8,170	* 7,850	6,320	6,510	5,000	* 5,580	4,000	4,900	3,220	* 4,380	2,600	2,650	2,090	* 2,040	2,020	55'10"			
-10'	lb	* 5,810	* 5,810	* 7,400	* 7,400	* 10,910	10,910	* 14,030	10,330	10,600	7,600	* 8,420	5,870	* 6,950	4,660	* 5,920	3,750	* 5,150	3,040	4,520	2,470				* 2,340	2,050	54'7"		
-15'	lb	* 7,200	* 7,200	* 8,750	* 8,750	* 11,890	* 11,890	14,470	9,970	11,040	7,250	* 8,810	5,580	* 7,280	4,420	* 6,170	3,570	5,250	2,910	4,440	2,390				* 2,750	2,150	52'10"		
-20'	lb	* 8,630	* 8,630	* 10,260	* 10,260	* 13,310	* 13,310	14,540	9,870	11,230	7,100	* 9,010	5,420	* 7,450	4,290	6,180	3,470	5,180	2,840	* 3,930	2,360				* 3,320	2,330	50'6"		
-25'	lb	* 10,120	* 10,120	* 11,910	* 11,910	* 15,070	15,070	14,270	9,950	11,140	7,100	* 9,000	5,390	* 7,450	4,260	6,170	3,450	5,190	2,850							* 4,180	2,610	47'7"	
-30'	lb	* 11,690	* 11,690	* 13,720	* 13,720	* 17,180	16,130	13,620	10,200	10,740	7,240	* 8,720	5,490	* 7,220	4,330	* 6,030	3,530									* 5,230	3,080	43'11"	
-35'	lb	* 13,330	* 13,330	* 15,690	* 15,690	* 16,460	16,460	12,540	10,600	* 9,960	7,520	* 8,100	5,700	* 6,660	4,530											* 5,610	3,840	39'3"	
-40'	lb			* 17,810	* 17,810	* 14,040	14,040	* 10,840	10,840	* 8,650	7,970	* 6,970	6,080													* 6,050	5,280	33'2"	
-45'	lb																									* 6,550	* 6,550	24'7"	

### Notes:

- Do not attempt to lift or hold any load that is greater than these lift capacities at their specified lift point radius and heights. Weight of all accessories must be deducted from the above lift capacities.
- Lift capacities are based on machine standing on level, firm, and uniform ground. User must make allowance for job conditions such as soft or uneven ground, out of level conditions, side loads, sudden stopping of loads, hazardous conditions, experience of personnel, etc.
- Bucket lift hook is defined as lift point.
- The above lifting capacities are in compliance with SAE J/ISO 10567. They do not exceed 87 % of hydraulic lifting capacity or 75 % of tipping load. Lifting capacities marked with an asterisk (\*) are limited by hydraulic capacity rather than tipping load.
- Operator should be fully acquainted with the Operator's and Maintenance Instructions before operating this machine. Rules for safe operation of equipment should be adhered to at all times.
- Lift capacities apply to only machines as originally manufactured and normally equipped by KOBELCO CONSTRUCTION MACHINERY CO., LTD.

Note: This catalog may contain attachments and optional equipment that are not available in your area. And it may contain photographs of machines with specifications that differ from those of machines sold in your areas. Please consult your nearest KOBELCO distributor for those items you require. Due to our policy of continuous product improvements all designs and specifications are subject to change without advance notice. Copyright by **KOBELCO CONSTRUCTION MACHINERY CO., LTD.** No part of this catalog may be reproduced in any manner without notice.

## KOBELCO CONSTRUCTION MACHINERY U.S.A. INC.

4690 World Houston Parkway Houston, TX 77032  
http://www.kobelco-usa.com/

Inquiries To: