

MINI EXCAVATORS

SR-5 Series

SK27SR SK35SR

SK27SR CANOPY		Long arm: 4'6" (1.37 m) Shoe: 10" (250 mm)							
		5' (1.5 m)		7.5' (2.3 m)		10' (3.0 m)		12.5' (3.8m)	
A									
B									
10' (3.0 m)	lb (kg)					*750(340)	*750(340)		
7.5' (2.3 m)	lb (kg)					*820(370)	*820(370)		
5' (1.5 m)	lb (kg)			*1,330(600)	1,330(600)	*1,040(470)	870(390)	*850(380)	610(270)
2.5' (0.8 m)	lb (kg)			*2,030(920)	1,260(570)	*1,320(600)	800(360)	*920(420)	580(260)
G. L.	lb (kg)	*2,010(910)	*2,010(910)	*2,390(1,080)	1,190(540)	*1,510(680)	760(340)	*1,030(470)	560(250)
-2.5' (-0.8 m)	lb (kg)	*3,250(1,470)	2,380(1,080)	*2,360(1,070)	1,170(530)	*1,520(690)	750(340)	*1,110(500)	540(240)
-5' (-1.5 m)	lb (kg)	*3,520(1,590)	2,430(1,100)	*1,970(890)	1,190(540)	*1,240(560)	760(340)	*1,040(470)	530(240)

SK35SR CANOPY		Standard arm: 4'4" (1.32 m) Shoe: 12" (300 mm)									
		5' (1.5 m)		7.5' (2.3 m)		10' (3.0 m)		12.5' (3.8m)		15' (4.6m)	
A											
B											
10' (3.0 m)	lb (kg)							*1,190(540)	1,120(510)		
7.5' (2.3 m)	lb (kg)					*1,380(620)	*1,380(620)	*1,280(580)	1,100(500)		
5' (1.5 m)	lb (kg)			*2,760(1,250)	2,380(1,080)	*1,830(830)	1,510(680)	*1,480(670)	1,050(470)		
2.5' (0.8 m)	lb (kg)			*3,760(1,700)	2,180(990)	*2,270(1,030)	1,420(640)	*1,690(760)	1,000(450)	*1,390(630)	750(340)
G. L.	lb (kg)	*2,550(1,150)	*2,550(1,150)	*4,020(1,820)	2,120(960)	*2,520(1,140)	1,360(610)	*1,820(820)	970(440)		
-2.5' (-0.8 m)	lb (kg)	*4,080(1,850)	*4,080(1,850)	*3,830(1,740)	2,120(960)	*2,520(1,140)	1,340(610)	*1,800(810)	960(430)		
-5' (-1.5 m)	lb (kg)	*5,790(2,620)	4,550(2,060)	*3,290(1,490)	2,150(970)	*2,210(1,000)	1,360(620)				
-7.5' (-2.3 m)	lb (kg)	*3,470(1,570)	*3,470(1,570)	*2,110(950)	*2,110(950)						

SK35SR CAB		Standard arm: 4'4" (1.32 m) Shoe: 12" (300 mm)									
		5' (1.5 m)		7.5' (2.3 m)		10' (3.0 m)		12.5' (3.8m)		15' (4.6m)	
A											
B											
10' (3.0 m)	lb (kg)							*1,190(540)	*1,190(540)		
7.5' (2.3 m)	lb (kg)							*1,280(580)	1,160(530)		
5' (1.5 m)	lb (kg)			*2,760(1,250)	2,510(1,140)	*1,830(830)	1,600(720)	*1,480(670)	1,120(500)		
2.5' (0.8 m)	lb (kg)			*3,760(1,700)	2,310(1,050)	*2,270(1,030)	1,500(680)	*1,690(760)	1,070(480)	*1,390(630)	800(360)
G. L.	lb (kg)	*2,550(1,150)	*2,550(1,150)	*4,020(1,820)	2,250(1,020)	*2,520(1,140)	1,450(650)	*1,820(820)	1,040(470)		
-2.5' (-0.8 m)	lb (kg)	*4,080(1,850)	*4,080(1,850)	*3,830(1,740)	2,250(1,020)	*2,520(1,140)	1,430(650)	*1,800(810)	1,030(460)		
-5' (-1.5 m)	lb (kg)	*5,790(2,620)	4,800(2,180)	*3,290(1,490)	2,280(1,030)	*2,210(1,000)	1,450(660)				
-7.5' (-2.3 m)	lb (kg)	*3,470(1,570)	*3,470(1,570)	*2,110(950)	*2,110(950)						

SK35SR CANOPY		Long arm: 5'3" (1.59 m) Shoe: 12" (300 mm)									
		5' (1.5 m)		7.5' (2.3 m)		10' (3.0 m)		12.5' (3.8m)		15' (4.6m)	
A											
B											
10' (3.0 m)	lb (kg)							*1,010(450)	*1,010(450)		
7.5' (2.3 m)	lb (kg)					*1,140(510)	*1,140(510)	*1,120(510)	1,100(500)	*1,120(510)	780(350)
5' (1.5 m)	lb (kg)			*2,260(1,020)	*2,260(1,020)	*1,600(720)	1,520(690)	*1,340(600)	1,050(470)	*1,210(540)	760(340)
2.5' (0.8 m)	lb (kg)			*3,430(1,550)	2,210(1,000)	*2,090(950)	1,420(640)	*1,570(710)	1,000(450)	*1,310(590)	730(330)
G. L.	lb (kg)	*2,310(1,040)	*2,310(1,040)	*3,930(1,780)	2,100(950)	*2,420(1,100)	1,350(610)	*1,750(790)	950(430)	*1,380(630)	710(320)
-2.5' (-0.8 m)	lb (kg)	*3,540(1,600)	*3,540(1,600)	*3,910(1,770)	2,080(940)	*2,510(1,140)	1,320(590)	*1,800(810)	930(420)		
-5' (-1.5 m)	lb (kg)	*4,990(2,260)	4,440(2,010)	*3,520(1,590)	2,100(950)	*2,330(1,050)	1,320(600)	*1,620(730)	940(430)		
-7.5' (-2.3 m)	lb (kg)	*4,610(2,090)	4,580(2,070)	*2,620(1,180)	2,170(980)						

- Notes:
- Do not attempt to lift or hold any load that is greater than these rated values at their specified load radius and height. Weight of all accessories must be deducted from the above lifting capacities.
 - Lifting capacities are based on machine standing on level, firm, and uniform ground. User must make allowance for job conditions such as soft or uneven ground out of level conditions, sudden stopping of loads, hazardous conditions, experience of personnel, etc.
 - Ratings at bucket lift hook.
 - The above rated loads are in compliance with SAE Hydraulic Excavator Lift Capacity Rating Standard J 1097. They do not exceed 87% of hydraulic lifting capacity or 75% of tipping load. Rated loads marked with asterisk (*) are limited by hydraulic capacity rather than tipping load.
 - Operator should be fully acquainted with the Operator's and Maintenance Instructions before operating this machine and rules for safe operation of equipment should be adhered to at all times.
 - Capacities apply to only machine as originally manufactured and normally equipped by KOBELCO CONSTRUCTION MACHINERY CO., LTD.

Note: This catalog may contain attachments and optional equipment that are not available in your area. It may also contain photographs of machines with specifications that differ from those of machines sold in your area. Please consult your nearest KOBELCO distributor for those items you require. Due to our policy of continuous product improvements all designs and specifications are subject to change without advance notice. Copyright by KOBELCO CONSTRUCTION MACHINERY CO., LTD. No part of this catalog may be reproduced in any manner without notice.

KOBELCO CONSTRUCTION MACHINERY U.S.A. INC.

4690 World Houston Parkway Houston, TX 77032
<http://www.kobelco-usa.com/>

Inquiries To:



An Evolutionary Leap: The Ultra-Compact Yet Tough SR-5 Series

Mini excavators are the machine of choice for small jobs where space is limited, like garden construction and pipe laying. In addition to their minimized tail swing radius, minis have also developed excellent performance characteristics and maneuverability that have broadened their usefulness for many different types of jobs.

Now, KOBELCO has taken the next evolutionary step by packing even more digging power and practical performance features into the new SR-5 Series while maintaining zero tail swing. No matter what the operation—digging, swinging, loading or dozing—these machines deliver unprecedented performance that will be profitable for owners while fully satisfying the most demanding operator. The SR-5 Series offers further refinement of the reliable mechanisms that have earned KOBELCO a reputation for excellence around the world. But that's not all. Our engineers have also kept the environment in mind when developing their designs, ensuring that the SR-5 machines pass all of the latest exhaust-gas regulations. Thanks to KOBELCO, mini excavators have just taken an evolutionary leap forward, with more powerful performance packed into less space than ever before.



- 1 Ample Performance: Capacity, Power and Speed**
Operability, ability to work well in small spaces, excellent side-ditch digging performance
- 2 Profitable Operation**
Zero swing radius means safe operation to the rear, minimizing repair costs and allowing the operator to concentrate efficiently on the job at hand
- 3 Highly Reliable Construction**
Construction that supports high-level performance
- 4 Easy Maintenance**
Quick and easy daily machine care
- 5 Comfortable Work Environment**
Long hours of operation without fatigue

Fast, Full-Powered Digging and Leveling

Powerful Digging

The SR-5 mini excavators are built for hard work. Thanks to IFPS (Integrated-Flow Pump System) and a large capacity engine, the hydraulic flow is more efficient than ever before, with a sensitive responsiveness that reduces cycle times. This combination of tough power and speed greatly increases hourly digging capacity.

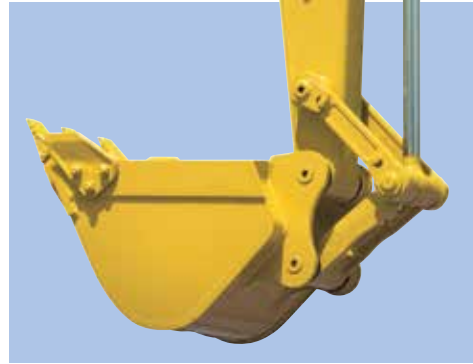

Integrated-Flow Pump System (Three Pumps)

The instant the machine begins to dig, extra output from the third pump (which otherwise powers the swing and dozer circuit) is directed to the arm circuit for added power. This ensures fast and smooth arm operation even under heavy loads.

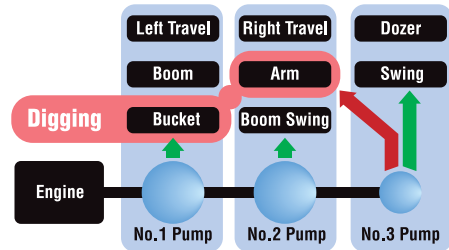

Large-Capacity Engine

The large-capacity engine meets Tier III requirements and packs plenty of power for outstanding hydraulic performance.

Smooth, Precise Lever Control

The control valves are carefully adjusted to precisely regulate hydraulic flow when the attachment and other systems begin moving, providing the operator with smooth, pinpoint control.

Attachment lever touch

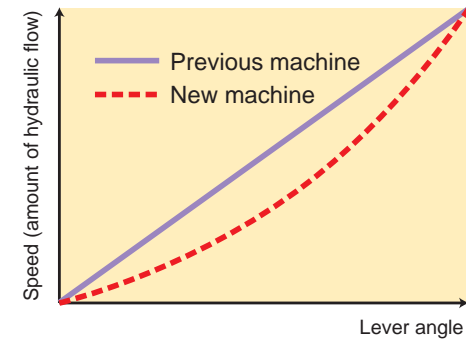

More Travel Power

Larger-capacity travel motors provide more travel torque, resulting in powerful travel.

Automatic Two-Speed Travel

An automatic shift function ensures smoother, more efficient travel on the worksite. The large capacity travel torque enables the machine to perform spin turn in low mode even when the dozer is pushing a heavy load.



The travel lever is fitted with a button for easy switching to Hi-Mode travel.

Optional Steel Shoes/Rubber-padded Shoes

The steel shoes have holes that hold specially designed rubber pads to protect the road surface.



Steel shoes



Rubber-padded shoes

Powerful and Efficient Dozer Performance

Dozer operations are an indispensable part of pipe laying, ditch digging, and other jobs that require leveling, compacting and refilling. To meet this need, the SR-5 mini excavators combine a powerful travel system with a highly efficient dozer blade that moves earth with less waste. The result: more work is completed in less time.



New Dozer-Blade Shape

KOBELCO's unique blade design solves this problem by forming the earth into an arc that always falls forward. Because this prevents earth from falling behind the blade, only "one pass" is needed. (Patent pending)

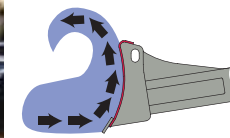

Maximum Approach Angle of 38°

The dozer blade can be raised much higher than before. With a maximum approach angle 38°, it's easy to ride the machine up over mounds of earth, or to load the machine onto a truck for transport.

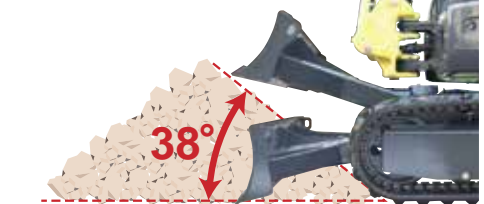

Zero tail Swing and Excellent Side-Ditch Digging

Excellent Safety and Operating Efficiency

The zero tail swing means that the operator doesn't have to worry about the rear of the machine when swinging. He can concentrate instead on the job in front of him, which increases performance efficiency.

Tail overhang: **0 mm***



Boom Offset Function

The boom offset function makes it possible to do parallel digging without moving the undercarriage, resulting in precise and safe ditch digging and pipe laying operations.

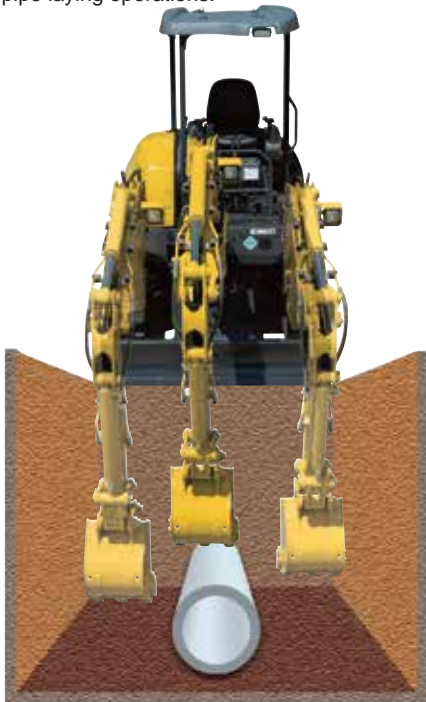

Small Operating Footprint

The combination of the side-ditch digging function and zero tail radius makes it easy to dig next to walls, with a compact operating footprint that makes digging, swinging and dumping possible in very limited spaces.



Optimized Bucket/Blade Positioning

The distance between the bucket and dozer blade has been minimized to make surface sweeping more convenient.



Hydraulic Pilot-Controlled Dozer Operation Lever



The dozer lever features hydraulic pilot control for precise handling.

NEW 4-WAY BLADE OPTION

Brand new from Kobelco is a 4-way blade option available on the SK35SR. Built with the same durability as the standard blade, this 4-way option provides 23 to 25° degrees of left and right angle movement for clearing, grading and back-filling. The 4-way blade gives you better control for following changing terrain, and helps eliminate the windrowing effect that can occur with standard dozer blades. With all of these new options, the new Kobelco Tier IV compact excavators are "Your Competitive Edge" for increased profitability.

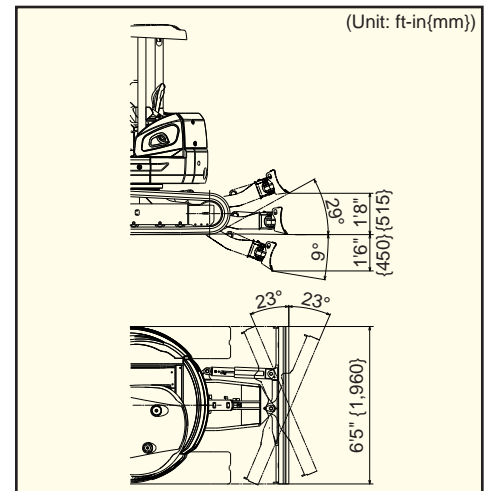

Exceptional Endurance

Highly Reliable Construction

The boom, arm, and swing bracket all have large cross-section areas that provide added strength to the attachment. This mechanical strength is complemented by a high-strength power line and enhanced cooling function for even more solid power.

Stronger Boom and Arm

1. Forged boom top
2. Self-locking pins firmly lock the boom and arm to prevent the boom top from opening laterally.
3. Stronger box-section boom
4. Reinforced arm handles diverse applications.

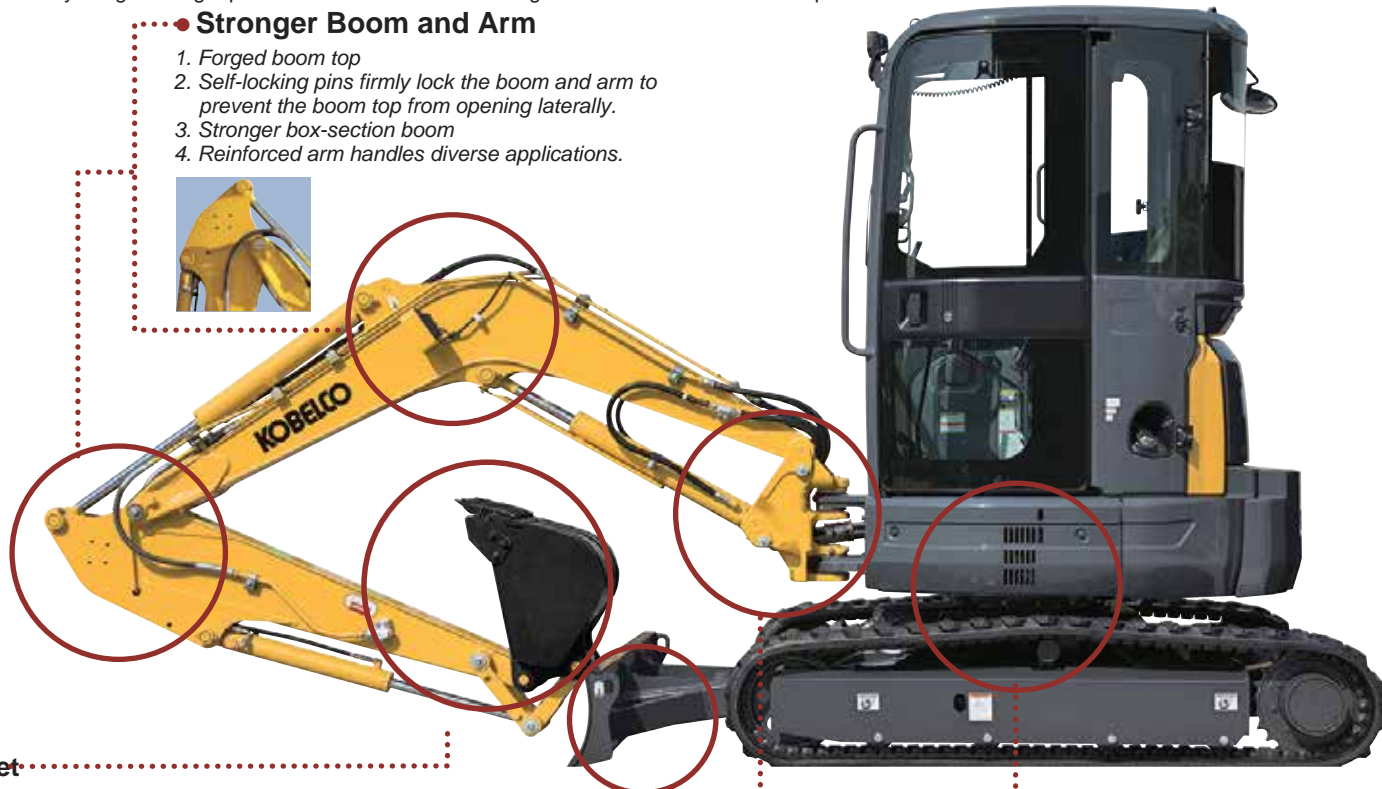

Bucket

1. Cast idler links provide greater strength.
2. The bucket's hydraulic piping passes through the arm bracket for added protection.



3. Plate pins prevent idler-pin rotation.

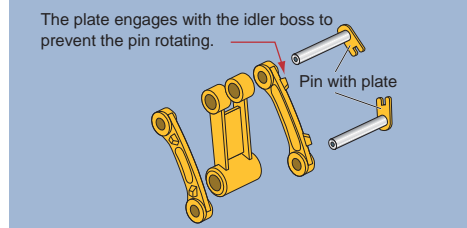

4. Newly shaped bucket

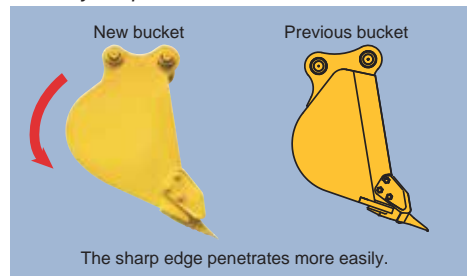

Dozer

1. Increased torsional strength in dozer arms
2. Dozer's hydraulic piping is easily replaced
3. Dozer cylinder cover



Swing Bracket

1. Large, thick cast-iron swing bracket
2. Plate-type pin prevents unwanted rotation

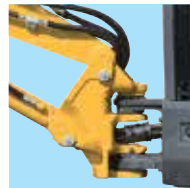

Reinforced Lower Structure



Outstanding Cooling Performance

The high-performance, high-capacity radiator and oil cooler, coupled with larger engine-oil capacity, deliver a heat balance that's comparable to a full size machine.



Highly Reliable Power Plant

The size of many of the engine components has been increased for improved reliability, including: a large battery, large-capacity radiator, large capacity oil cooler, and increased starter-motor and alternator capacities.

Large-Size Components

1. Breather prevents malfunctions in hydraulic components.
2. Large battery and large-capacity radiator
3. Large-capacity oil cooler
4. Increased starter-motor capacity
5. Increased alternator capacity

Easy Maintenance

Easy Daily Maintenance

Start-up checks are essential for safe and reliable machine operation. With the SR-5 machines, all start-up checks can be performed at ground level, with an easy-to-understand layout and cover design that simplifies access and reduces maintenance check times.

Routine Maintenance

Ground-level start-up checks



- 1 Hour meter can be checked from the ground.



- 2 Fuel tank can be filled from the ground.
- Resin fuel tank resists rust and is removable for easy cleaning.



- 3 Right cover has a small window that makes N&B selection easily.



- 4 A compartment cover under the seat provides easy access to electrical components.



- 5 Wider opening cover provides easy access to valves.



Easy Cleaning



- 6 Radiator is easy to clean.



- 7 Two-piece floor mats for easy washing.
- The floor plate has no projections, making it easy to wash down and wipe dry.



- 8 No tools needed for fuel-tank drain cock.



- 9 Engine oil filter

• Quick drain for engine oil provided as standard.

Exclusive Super-Fine Filter (Hydraulic oil filter)

This exclusive super-fine filter is environmentally friendly, lasts 1,000 hours, and is easy to replace.

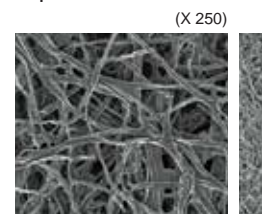

Conventional filter

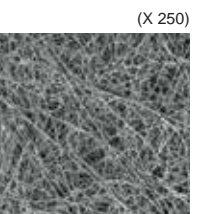

Super fine filter

Comfortable Work Environment

Spacious Work Environment

Broader floor space and a greater sliding range for the seat give operators plenty of foot room. Wide operational space is provided with more room between the left and right control consoles.



Easy Access

A wide-opening door and a left-hand control box with safety lever that rises higher than before, make it much easier for operators to enter and exit the cab.

Wide Cab Entryway

1. Wider door opening
2. Front-window link does not obstruct cab entryway
3. Large, sturdy door handle



door handle

The Most Foot Room in Its Class

The seat has ample space for sliding forward and back.

Visibility

Wider front window ensures an open, panoramic view.



Work Lights

Work lights have been added on both sides to provide a clear view during nighttime operations.



Operator Safety

Newly Developed ROPS Cab

Mandrel bent tubing is used in the cab frame to increase rigidity, resulting in a 50% increase in durability and service life.



Exclusive, Newly Designed ROPS/FOPS Canopy

The newly designed three-support ROPS/FOPS canopy ensures easy access, and provides an open view of digging operations when swinging.



Note: Specifications for the cab and canopy differ depending on the region.

Amenities

Levers, instruments, and other accessories have been laid out with a priority placed on ease of use, straightforward access, ergonomic positioning, and clear visibility.



Monitor display panel set at an easy-to-read angle
Storage compartment for personal items



Front window features gas damper cylinders for smooth and easy opening.



Easy-access, easy-turn ignition with rubber boots for protection against moisture and freezing



Air conditioner switch



Cup holder



Room light, coat hook and safety hammer



Retractable seat belt



Wrist rest

SPECIFICATIONS

GENERAL			
MODEL		SK27SR	SK35SR
Type		SK27SR-5	SK35SR-5
Machine Mass	Cab	lbs (kg)	5,870 {2,660}
	Canopy	lbs (kg)	5,560 {2,520}
Bucket Capacity		cu ft (m ³)	2.82 {0.08}
Bucket Width (With Side Cutter)		ft-in (mm)	1'8" {500}
Arm Length		ft-in (m)	3'8" {1.12}
Bucket Digging Force (SAE) * 2 pin position bucket		lbf (kN)	6,341 {28.2}
Arm Crowding Force (SAE)		lbf (kN)	3,190 {14.2}
ENGINE			
Model		YANMAR 3TNV82A-SYB	YANMAR 3TNV88-BPYB
Type		Water-cooled, 4 cycle, 3 cylinder, direct injection, diesel	
Power Output		hp {kW} / rpm	21.3 / 2,200 {15.9 / 2,200} (SAE NET)
Max. Torque		lbf-ft {N·m} / rpm	58.3 / 1,320 {79.0 / 1,320} (SAE NET)
Displacement		cu in {L}	81.2 {1.33}
Fuel Tank		gal {L}	7.4 {28}
HYDRAULIC SYSTEM			
Pumps		Two variable displacement pumps	
Max. Flow		U.S.gal / min {L/min}	2 x 7.0 {2 x 26.4}
Relief Valve Setting		psi {Mpa}	3,335 {23}
Hydraulic Oil Tank (System)		gal {L}	5.3 (6.6) {20 (25)}
TRAVEL SYSTEM			
Travel Motor		2 x Axial piston motor	
Parking Brake		Oil disk brake per motor	
Travel Speed (High Low)		mph {km/h}	2.5 {4.1} 1.4 {2.3}
CRAWLER			
Shoe Width		in {mm}	10" {250}
Ground Pressure	Cab	psi {kpa}	4.35 {30.0}
	Canopy	psi {kpa}	4.06 {28.0}
DOZER BLADE			
Width x Height		ft-in {mm}	4'11" {1,500} x 12" {300}
Working Ranges (Height/Depth)		ft-in {mm}	1'6" {445} / 1'1" {335}
SWING SYSTEM			
Swing Motor		Axial piston motor	
Parking Brake		Oil disc brake, hydraulic operated automatically	
Swing Speed		min ⁻¹ {rpm}	8.7
Tail Swing Radius		ft-in {mm}	2'6" {750}
Min. Front Swing Radius	Over The Front	Cab	ft-in {mm}
		Canopy	ft-in {mm}
	At Full Boom Swing	Cab	ft-in {mm}
		Canopy	ft-in {mm}
SIDE DIGGING MECHANISM			
Type		Boom swing	
Offset Angle	To The Left	degree	60
	To The Right	degree	55

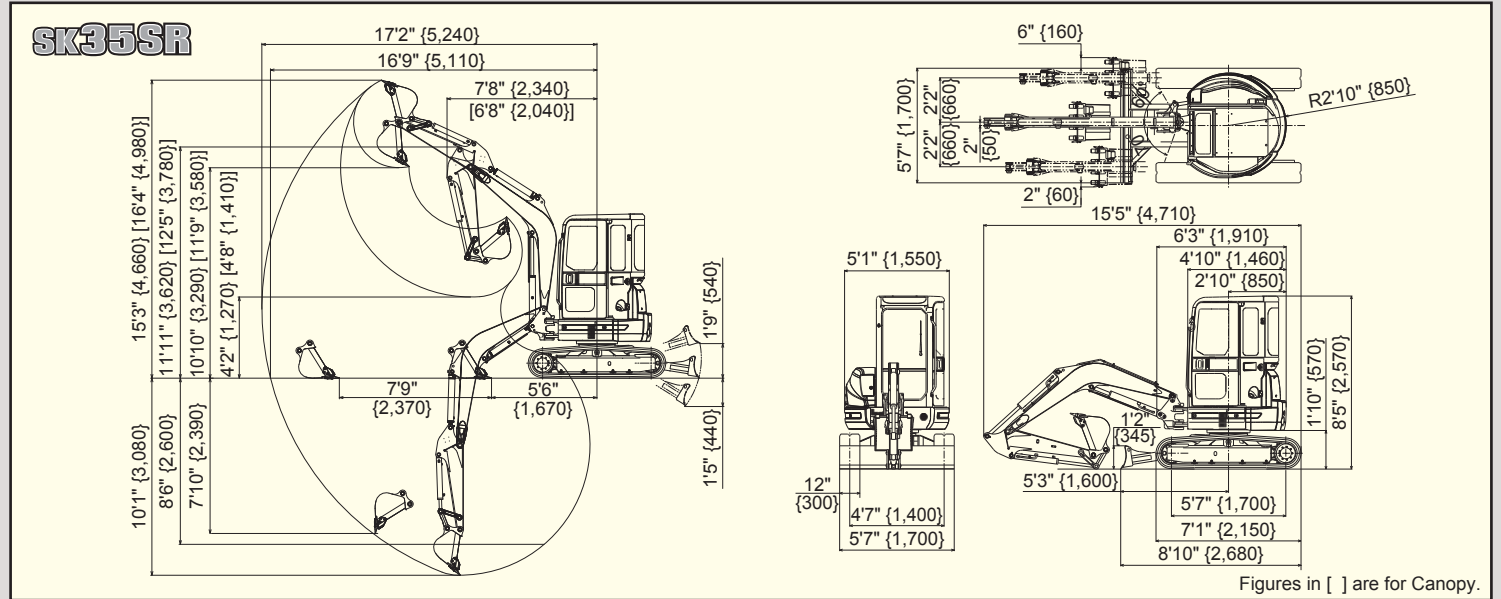

Figures in [] are for Canopy.

4-WAY BLADE (OPTION) (SK35SR only)

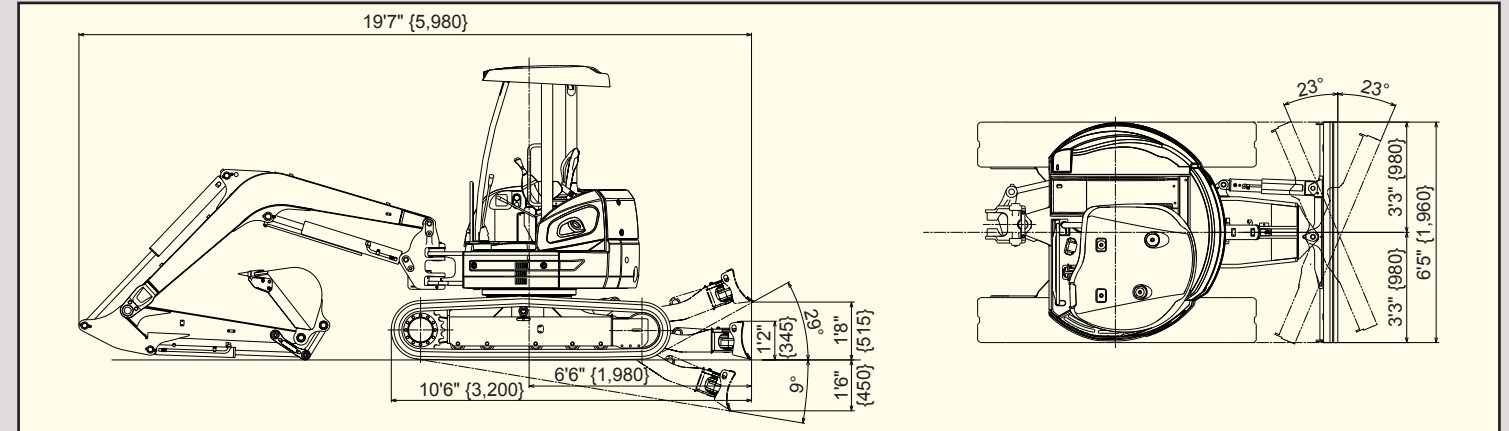

LIFTING CAPACITY

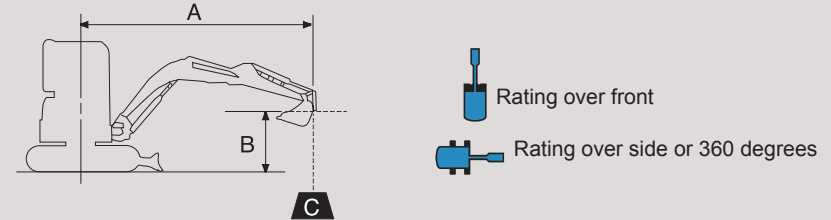

A: Reach from swing centerline to bucket hook
 B: Bucket hook height above/below ground
 C: Lifting capacities in pounds
 Shoe: Rubber shoe Dozer blade: Down
 Relief valve setting: 3,335psi {23}MPa

WORKING RANGES & DIMENSIONS

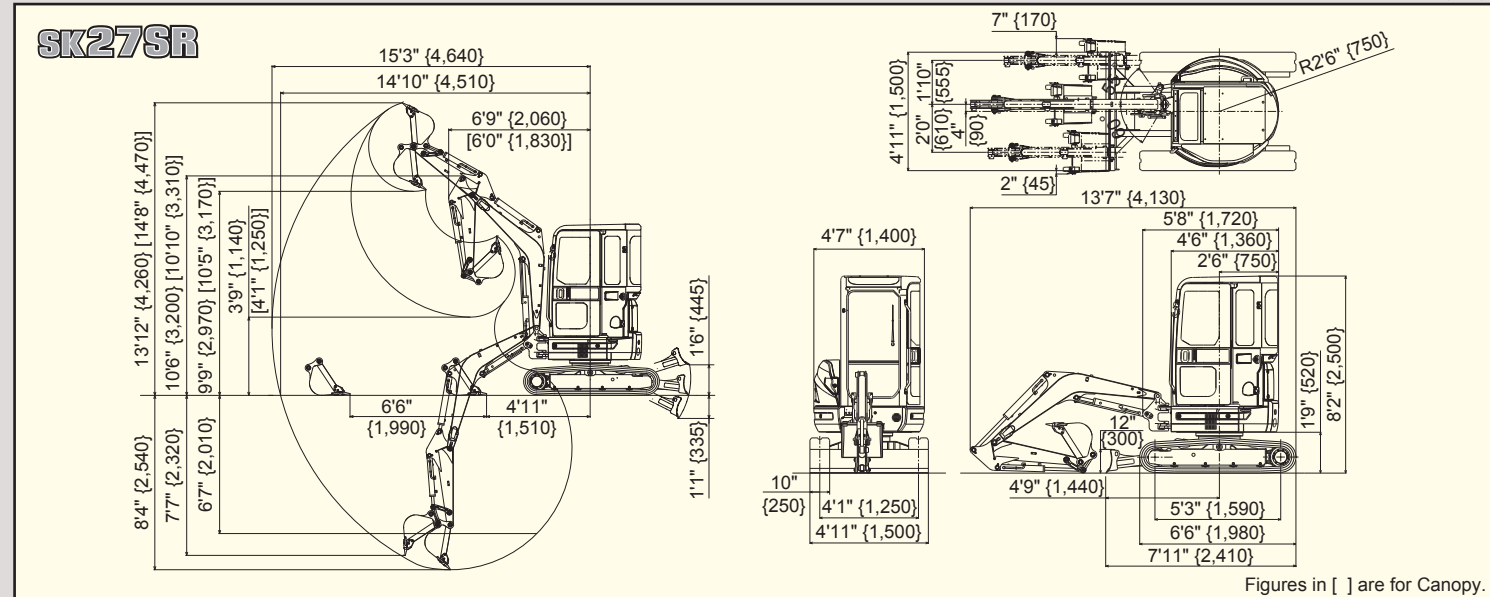

Figures in [] are for Canopy.

SK27SR CANOPY		Standard arm: 3'8" {1.12 m} Shoe: 10" {250 mm}							
A		5' {1.5 m}		7.5' {2.3 m}		10' {3.0 m}		12.5' {3.8 m}	
B	10' {3.0 m}	Rating over front	Rating over side or 360 degrees	Rating over front	Rating over side or 360 degrees	Rating over front	Rating over side or 360 degrees	Rating over front	Rating over side or 360 degrees
	7.5' {2.3 m}								
	5' {1.5 m}			*1,600{720}	1,380{620}	*1,180{530}	870{390}	*1,020{460}	590{270}
	2.5' {0.8 m}			*2,230{1,010}	1,260{570}	*1,420{640}	810{370}	*1,100{500}	570{260}
G. L.	lb (kg)	*2,250{1,020}	*2,250{1,020}	*2,450{1,110}	1,200{540}	*1,560{710}	780{350}	*1,130{510}	550{250}
	-2.5' {-0.8 m}	*3,860{1,750}	2,440{1,100}	*2,300{1,040}	1,200{540}	*1,500{680}	770{350}		
	-5' {-1.5 m}	*2,980{1,350}	2,510{1,130}	*1,760{800}	1,240{560}				
SK27SR CAB		Standard arm: 3'8" {1.12 m} Shoe: 10" {250 mm}							
A		5' {1.5 m}		7.5' {2.3 m}		10' {3.0 m}		12.5' {3.8 m}	
B	10' {3.0 m}	Rating over front	Rating over side or 360 degrees	Rating over front	Rating over side or 360 degrees	Rating over front	Rating over side or 360 degrees	Rating over front	Rating over side or 360 degrees
	7.5' {2.3 m}								
	5' {1.5 m}			*1,600{720}	1,490{670}	*1,180{530}	940{420}	*1,020{460}	650{290}
	2.5' {0.8 m}			*2,230{1,010}	1,360{620}	*1,420{640}	890{400}	*1,100{500}	620{280}
G. L.	lb (kg)	*2,250{1,020}	*2,250{1,020}	*2,450{1,110}	1,310{590}	*1,560{710}	850{380}	*1,130{510}	610{270}
	-2.5' {-0.8 m}	*3,860{1,750}	2,640{1,200}	*2,300{1,040}	1,310{590}	*1,500{680}	850{380}		
	-5' {-1.5 m}	*2,980{1,350}	2,710{1,230}	*1,760{800}	1,350{610}				