

# Lifting Capacities

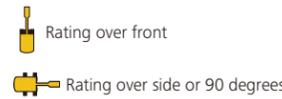
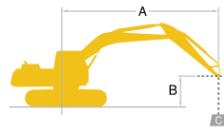

A – Reach from swing centerline to arm tip  
 B – Arm bucket pin height above/below ground  
 C – Lifting capacities in pounds (kilograms)  
 Relief valve setting: 4,970 psi

SK500LC		Standard Arm: 11' 4" (3.45 m)		Without bucket		Shoe: 31.5" (800 mm)		20' (6.1 m)		25' (7.6 m)		30' (9.1 m)		At. Max. reach		HEAVY LIFT	
A		10' (3.0 m)		15' (4.6 m)												Radius	
B																	
30' (9.1 m)	lb (kg)																
25' (7.6 m)	lb (kg)																
20' (6.1 m)	lb (kg)																
15' (4.6 m)	lb (kg)																
10' (3.0 m)	lb (kg)																
5' (1.5 m)	lb (kg)																
G. L.	lb (kg)																
-5' (-1.5 m)	lb (kg)																
-10' (-3.0 m)	lb (kg)																
-15' (-4.6 m)	lb (kg)																

SK500LC		Semi-long Arm: 13' 3" (4.04 m)		Without bucket		Shoe: 31.5" (800 mm)		20' (6.1 m)		25' (7.6 m)		30' (9.1 m)		35' (10.7 m)		At. Max. reach		HEAVY LIFT	
A		5' (1.5 m)		10' (3.0 m)		15' (4.6 m)												Radius	
B																			
30' (9.1 m)	lb (kg)																		
25' (7.6 m)	lb (kg)																		
20' (6.1 m)	lb (kg)																		
15' (4.6 m)	lb (kg)																		
10' (3.0 m)	lb (kg)																		
5' (1.5 m)	lb (kg)																		
G. L.	lb (kg)																		
-5' (-1.5 m)	lb (kg)																		
-10' (-3.0 m)	lb (kg)																		
-15' (-4.6 m)	lb (kg)																		
-20' (-6.1 m)	lb (kg)																		

SK500LC		Long Arm: 16' 1" (4.90 m)		Without bucket		Shoe: 31.5" (800 mm)		20' (6.1 m)		25' (7.6 m)		30' (9.1 m)		35' (10.7 m)		At. Max. reach		HEAVY LIFT	
A		5' (1.5 m)		10' (3.0 m)		15' (4.6 m)												Radius	
B																			
30' (9.1 m)	lb (kg)																		
25' (7.6 m)	lb (kg)																		
20' (6.1 m)	lb (kg)																		
15' (4.6 m)	lb (kg)																		
10' (3.0 m)	lb (kg)																		
5' (1.5 m)	lb (kg)																		
G. L.	lb (kg)																		
-5' (-1.5 m)	lb (kg)																		
-10' (-3.0 m)	lb (kg)																		
-15' (-4.6 m)	lb (kg)																		
-20' (-6.1 m)	lb (kg)																		

- Notes:
- Do not attempt to lift or hold any load that is greater than these lifting capacities at their specified lift point radius and heights. Weight of all accessories must be deducted from the above lifting capacities.
  - Lifting capacities are based on machine standing on level, firm, and uniform ground. User must make allowance for job conditions such as soft or uneven ground, out of level conditions, side loads, sudden stopping of loads, hazardous conditions, experience of personnel, etc.
  - Arm bucket pin, without bucket is defined as lift point.
  - The above lifting capacities are in compliance with SAE J1505. They do not exceed 87 % of hydraulic lifting capacity or 75 % of tipping load.
  - Lifting capacities marked with an asterisk (\*) are limited by hydraulic capacity rather than tipping load.
  - Operator should be fully acquainted with the Operator's and Maintenance Instructions before operating this machine. Rules for safe operation of equipment should be adhered to at all times.
  - Lifting capacities apply to only machines as originally manufactured and normally equipped by KOBELCO CONSTRUCTION MACHINERY CO., LTD.

Note: This catalog may contain attachments and optional equipment that are not available in your area. And it may contain photographs of machines with specifications that differ from those of machines sold in your areas. Please consult your nearest KOBELCO distributor for those items you require. Due to our policy of continuous product improvements all designs and specifications are subject to change without advance notice. Copyright by KOBELCO CONSTRUCTION MACHINERY CO., LTD. No part of this catalog may be reproduced in any manner without notice.

## KOBELCO CONSTRUCTION MACHINERY U.S.A. INC.

22350 Merchants Way, Katy, Texas 77449  
<http://www.kobelco-usa.com/>

Inquiries To:

High & Wide-NA-303-1905001

# KOBELCO

## Hydraulic Excavator

SK210 LC SK260 LC  
 SK300 LC SK350 LC  
 SK500 LC  
 High & Wide Specifications

DRIVEN BY PASSION

### ■ Bucket Capacity :

- 1.05 cu yd SAE: SK210LC
- 1.31 cu yd SAE: SK260LC
- 1.57 cu yd SAE: SK300LC
- 1.83 cu yd SAE: SK350LC
- 2.49 cu yd SAE: SK500LC

### ■ Engine Power (SAE NET):

- 160 hp {119 kW} @ 2,000 rpm: SK210LC
- 178 hp {133 kW} @ 2,100 rpm: SK260LC
- 252 hp {188 kW} @ 2,100 rpm: SK300LC
- 270 hp {201 kW} @ 2,100 rpm: SK350LC
- 369 hp {271 kW} @ 1,850 rpm: SK500LC

### ■ Operating Weight :

- 56,700 lbs {25,700 kg}: SK210LC
- 63,100 lbs {28,600 kg}: SK260LC
- 73,600 lbs {33,400 kg}: SK300LC
- 87,700 lbs {39,800 kg}: SK350LC
- 124,800 lbs {56,600 kg}: SK500LC



Complies with the latest exhaust emission regulations

US EPA  
Tier IV Final

EU (NRMM)  
Stage IV

Japanese  
Regulations

# Power Meets Efficiency

A new line-up specially equipped for forestry and hilly terrain work has been added to the SK excavator series famous for outstanding productivity and extremely low fuel consumption.

The High & Wide Specification series have the generous ground clearance needed to penetrate sites littered with stumps or rocks. The extra crawler width ensures excellent stability, contributing to uninterrupted working and greater lifting capacity.

Durability is significantly improved with full track guides and larger upper rollers for the crawlers, to prevent de-tracking.

With double grouser shoes used for better grip, these machines are designed to work smoothly over the roughest ground.



## Productivity

### More Power and Higher Efficiency

The highly efficient hydraulic system minimizes fuel consumption while maximizing power. With nimble movement and outstanding digging power, these excavators improve job productivity.

## Performance

### Excellent Stability

Overall width of crawlers is greater than standard models, for dependable stability and improved lifting capacity.



Overall width of crawlers

- 11' (3,340 mm): SK210LC
  - 11' 8" (3,550 mm): SK260LC
  - 11' 11.5" (3,650 mm): SK300LC
  - 11' 11.5" (3,650 mm): SK350LC
  - 13' 2" (4,020 mm): SK500LC
- \*Overall width: Extended

### Generous ground clearance

Travel is unhampered on forestry sites and in hilly terrain strewn with stumps and rocks.



Ground clearance

- 2' 6" (775 mm): SK210LC
- 2' 7" (780 mm): SK260LC
- 2' 7" (785 mm): SK300LC
- 2' 7" (785 mm): SK350LC
- 2' 10" (870 mm): SK500LC

## Durability



### Unbeatable durability

The crawlers are designed to provide unbeatable durability to take on the harshest terrain. They feature full track guides to eliminate de-tracking concerns, a reinforced guide frame built to withstand heavy impact, and large, double-support, outer flanged upper rollers unfazed by powerful vibrations.



1 Reinforced guide frame  
\* not applicable for SK500LC



2 Large, double-support, outer flanged upper rollers



3 Full track guide (optional)

## Specifications

MODEL		SK210LC-10	
Specification		High & Wide	
<b>PERFORMANCE</b>			
Bucket Capacity (SAE heaped)	cu yd (m <sup>3</sup> )	1.05 (0.80)	
Swing Speed	rpm (min <sup>-1</sup> )	12.7 (12.7)	
Swing Torque	lb-ft (kN-m)	52,700 (71.5)	
Travel Speed (high/low)	mph (km/h)	3.4/2.1 (5.5/3.4)	
Gradeability	% (degree)	70 (35)	
Bucket Digging Force	SAE lbf (kN)	28,800/31,700* (128/141*)	
	ISO lbf (kN)	32,100/35,300* (143/157*)	
Arm Crowding Force	SAE lbf (kN)	22,200/24,500* (98.8/109*)	
	ISO lbf (kN)	22,900/25,200* (102/112*)	
Drawbar Pulling Force	lbf (kN)	51,300 (228) (SAE J 1349)	
<b>WEIGHT</b>			
Operating Weight	lbs (kg)	56,700 (25,700)	
Ground Pressure	psi (kPa)	6.5 (45.1)	
Shoe Width	ft-in (mm)	28" (700)	
<b>ENGINE</b>			
Model	HINO J05ETM-KSSC		
Type	Direct injection, water-cooled, 4-cycle, 4-cylinder diesel engine with intercooler turbo-charger (Complies with EPA Tier IV Final)		
Power Output	(SAE NET) hp/rpm (kW/min <sup>-1</sup> )	160/2,000 (119/2,000)	
	(Without fan) hp/rpm (kW/min <sup>-1</sup> )	166/2,000 (124/2,000)	
Max. Torque	(SAE NET) lb-ft/rpm (N-m/min <sup>-1</sup> )	472/1,600 (640/1,600)	
	(Without fan) lb-ft/rpm (N-m/min <sup>-1</sup> )	487/1,600 (660/1,600)	
Displacement	cu in (L)	312.6 (5.123)	
Fuel Tank	US gal (L)	84.5 (320)	
DEF/AdBlue Tank	US gal (L)	21.9 (83)	
<b>HYDRAULIC SYSTEM</b>			
Pump	Two variable displacement pumps + one gear pump		
Max. Discharge Flow	US gpm (L/min)	58.1 (220) x 2 (main), 5.3 (20) x 1 (gear)	
Relief Valve Setting (main)/(Power Boost)	psi (MPa)	4,970 (34.3)/ {5,480 (37.8)}	
Swing Motor	Axial piston motor		
Travel Motors	2 x axial-piston, two-step motors		
Hydraulic Oil Tank (system)	US gal (L)	37.0 (140)/64.5 (244)	

\*Power Boost engaged

# SK210LC

## Working Ranges

Unit: ft-in (m)

	SK210LC High & Wide Spec.	
Boom	18' 6" (5.65)	
Arm length	Std.: 9' 8" (2.94)	Long: 11' 6" (3.50)
a- Max. digging reach	32' 6" (9.90)	33' 11" (10.34)
b- Max. digging reach at ground level	31' 8" (9.66)	33' 2" (10.11)
c- Max. digging depth	20' 10" (6.36)	22' 8" (6.92)
d- Max. digging height	33' (10.07)	33' 1" (10.09)
e- Max. dumping clearance	23' 9" (7.25)	24' 0" (7.32)
f- Min. dumping clearance	9' 1" (2.78)	7' 3" (2.22)
g- Max. vertical wall digging depth	18' 11" (5.76)	20' 1" (6.12)
h- Min. swing radius	11' 8" (3.55)	11' 5" (3.48)
i- Horizontal digging stroke at ground level	17' 6" (5.33)	20' 3" (6.16)
j- Digging depth for 8' (2.4 m) flat bottom	20' 3" (6.18)	22' 1" (6.74)
Bucket capacity (SAE heaped)	1.05 cu yd (0.80 m <sup>3</sup> )	0.92 cu yd (0.70 m <sup>3</sup> )

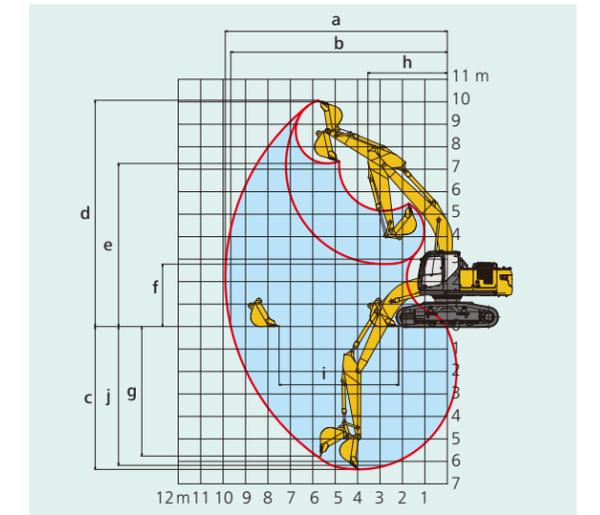

## General Dimensions

	SK210LC High & Wide Spec.	
Arm length	9' 8" (2,940)	11' 6" (3,500)
A Overall length	31' (9,450)	31' 3" (9,530)
B Overall height (to top of boom)	10' 5" (3,170)	10' 7" (3,230)
C Overall width	11' (3,340)	
D Overall height (to top of cab)	11' 3" (3,420)	
E Ground clearance of rear end*	4' 8" (1,410)	
F Ground clearance*	2' 6" (775)	

Unit: ft-in (mm)

G Tail swing radius	9' 7" (2,910)
G' Distance from center of swing to rear end	9' 6" (2,900)
H Tumbler distance	12' 1" (3,690)
I Overall length of crawler	15' (4,580)
J Track gauge	8' 8" (2,640)
K Shoe Width	28" (700)
L Overall width of upperstructure	9' 4" (2,850)

\*Without including height of shoe lug.

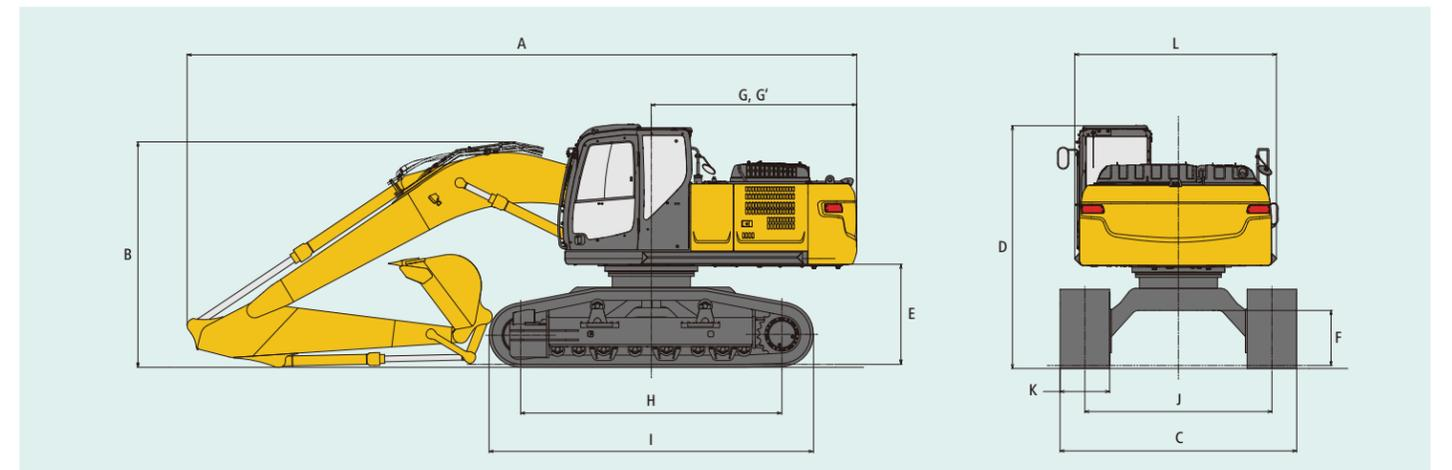

# Lifting Capacities

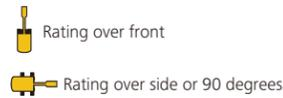
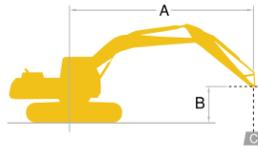

A – Reach from swing centerline to arm tip  
 B – Arm bucket pin height above/below ground  
 C – Lifting capacities in pounds (kilograms)  
 Relief valve setting: 5,480 psi

SK210LC		Standard Arm: 9' 8" (2.94 m)		Without bucket		Shoe: 28" (700 mm)		20' (6.1 m)		25' (7.6 m)		At. Max. reach		Radius
B	A	5' (1.5 m)	10' (3.0 m)	15' (4.6 m)	20' (6.1 m)	25' (7.6 m)	At. Max. reach	Radius						
25' (7.6 m)	lb (kg)				*12,300 (5,570)	*12,300 (5,570)			*9,360 (4,240)	*9,360 (4,240)			21' 2" (6.45 m)	
20' (6.1 m)	lb (kg)				*13,230 (6,000)	*13,230 (6,000)			*8,740 (3,960)	*8,740 (3,960)			24' 7" (7.49 m)	
15' (4.6 m)	lb (kg)			*17,170 (7,780)	*17,170 (7,780)	*14,550 (6,590)	14,370 (6,510)	*13,270 (6,010)	10,190 (4,620)	*8,620 (3,900)	*8,620 (3,900)		26' 7" (8.11 m)	
10' (3.0 m)	lb (kg)			*21,360 (9,680)	21,050 (9,540)	*16,440 (7,450)	13,770 (6,240)	13,890 (6,300)	9,930 (4,500)	*8,860 (4,010)	8,540 (3,870)		27' 7" (8.42 m)	
5' (1.5 m)	lb (kg)			*24,740 (11,220)	19,910 (9,030)	*18,190 (8,250)	13,210 (5,990)	13,600 (6,160)	9,660 (4,380)	*9,460 (4,290)	8,370 (3,790)		27' 8" (8.43 m)	
G.L.	lb (kg)		*16,750 (7,590)	*16,750 (7,590)	*26,020 (11,800)	19,350 (8,770)	18,530 (8,400)	12,850 (5,820)	13,420 (6,080)	9,490 (4,300)	*10,580 (4,790)	8,660 (3,920)	26' 9" (8.16 m)	
-5' (-1.5 m)	lb (kg)	*17,530 (7,950)	*17,530 (7,950)	*28,140 (12,760)	*28,140 (12,760)	19,250 (8,730)	18,410 (8,350)	12,740 (5,770)		*12,670 (5,740)	9,570 (4,340)		24' 10" (7.58 m)	
-10' (-3.0 m)	lb (kg)	*29,380 (13,320)	*29,380 (13,320)	*30,640 (13,890)	*30,640 (13,890)	*22,170 (10,050)	19,500 (8,840)	*16,170 (7,330)		*14,130 (6,400)	11,700 (5,300)		21' 7" (6.59 m)	
-15' (-4.6 m)	lb (kg)			*20,700 (9,380)	*20,700 (9,380)	*14,700 (6,660)	*14,700 (6,660)			*12,770 (5,790)	*12,770 (5,790)		16' 3" (4.97 m)	

SK210LC		Long Arm: 11' 6" (3.50 m)		Without bucket		Shoe: 28" (700 mm)		20' (6.1 m)		25' (7.6 m)		At. Max. reach		Radius
B	A	5' (1.5 m)	10' (3.0 m)	15' (4.6 m)	20' (6.1 m)	25' (7.6 m)	At. Max. reach	Radius						
25' (7.6 m)	lb (kg)								*8,040 (3,640)	*8,040 (3,640)			23' 0" (7.02 m)	
20' (6.1 m)	lb (kg)								*10,200 (4,620)	*10,200 (4,620)			26' 2" (7.98 m)	
15' (4.6 m)	lb (kg)					*13,340 (6,050)	*13,340 (6,050)	*12,300 (5,570)	10,260 (4,650)	*7,630 (3,460)	*7,630 (3,460)		28' 1" (8.57 m)	
10' (3.0 m)	lb (kg)			*30,480 (13,820)	*30,480 (13,820)	*19,580 (8,880)	*19,580 (8,880)	*15,390 (6,980)	13,890 (6,300)	*13,260 (6,010)	9,950 (4,510)	*7,890 (3,570)	29' 0" (8.86 m)	
5' (1.5 m)	lb (kg)			*16,180 (7,330)	*16,180 (7,330)	*23,510 (10,660)	20,130 (9,130)	*17,400 (7,890)	13,260 (6,010)	13,590 (6,160)	9,630 (4,360)	*8,460 (3,830)	29' 1" (8.87 m)	
G.L.	lb (kg)			*19,010 (8,620)	*19,010 (8,620)	*25,590 (11,600)	19,350 (8,770)	18,500 (8,390)	12,800 (5,800)	13,300 (6,040)	9,390 (4,250)	*9,480 (4,300)	28' 3" (8.61 m)	
-5' (-1.5 m)	lb (kg)	*16,640 (7,540)	*16,640 (7,540)	*27,100 (12,290)	*27,100 (12,290)	*25,590 (11,600)	19,090 (8,650)	18,280 (8,290)	12,600 (5,710)	13,240 (6,000)	9,310 (4,220)	*11,310 (5,130)	26' 5" (8.06 m)	
-10' (-3.0 m)	lb (kg)	*25,880 (11,730)	*25,880 (11,730)	*33,510 (15,190)	*33,510 (15,190)	*23,470 (10,640)	19,200 (8,700)	*17,330 (7,860)	12,670 (5,740)			*13,780 (6,250)	23' 5" (7.15 m)	
-15' (-4.6 m)	lb (kg)			*25,390 (11,510)	*25,390 (11,510)	*18,160 (8,230)	*18,160 (8,230)			*13,550 (6,140)	*13,550 (6,140)		18' 8" (5.69 m)	

- Notes:
- Do not attempt to lift or hold any load that is greater than these lifting capacities at their specified lift point radius and heights. Weight of all accessories must be deducted from the above lifting capacities.
  - Lifting capacities are based on machine standing on level, firm, and uniform ground. User must make allowance for job conditions such as soft or uneven ground, out of level conditions, side loads, sudden stopping of loads, hazardous conditions, experience of personnel, etc.
  - Arm bucket pin, without bucket is defined as lift point.
  - The above lifting capacities are in compliance with SAE J/ISO 10567. They do not exceed 87 % of hydraulic lifting capacity or 75 % of tipping load. Lifting capacities marked with an asterisk (\*) are limited by hydraulic capacity rather than tipping load.
  - Operator should be fully acquainted with the Operator's and Maintenance Instructions before operating this machine. Rules for safe operation of equipment should be adhered to at all times.
  - Lifting capacities apply to only machines as originally manufactured and normally equipped by KOBELCO CONSTRUCTION MACHINERY CO., LTD.

# Specifications

MODEL		SK260LC-10	
Specification		High & Wide	
<b>PERFORMANCE</b>			
Bucket Capacity (SAE heaped)	cu yd (m³)	1.31 (1.0)	
Swing Speed	rpm (min⁻¹)	10.2 (10.2)	
Swing Torque	lb-ft (kN-m)	63,300 (85.9)	
Travel Speed (high/low)	mph (km/h)	3.6/2.2 (5.8/3.6)	
Gradeability	% (degree)	70 (35)	
Bucket Digging Force	SAE lbf (kN)	35,000/38,500* (156/171*)	
	ISO lbf (kN)	38,200/42,000* (170/187*)	
Arm Crowding Force	SAE lbf (kN)	26,100/28,600* (116/127*)	
	ISO lbf (kN)	27,400/30,100* (122/134*)	
Drawbar Pulling Force	lbf (kN)	50,800 (226) (SAE J 1349)	
<b>WEIGHT</b>			
Operating Weight	lbs (kg)	63,100 (28,600)	
Ground Pressure	psi (kPa)	8.1 (56.1)	
Shoe Width	ft-in (mm)	28" (700)	
<b>ENGINE</b>			
Model	HINO JOSEUN-KSSD		
Type	Direct injection, water-cooled, 4-cycle, 4-cylinder diesel engine with intercooler turbo-charger (Complies with EPA Tier IV Final)		
Power Output	(SAE NET) hp/rpm (kW/min⁻¹)	178/2,100 (133/2,100)	
	(Without fan) hp/rpm (kW/min⁻¹)	185/2,100 (138/2,100)	
Max. Torque	(SAE NET) lb-ft/rpm (N-m/min⁻¹)	469/1,600 (636/1,600)	
	(Without fan) lb-ft/rpm (N-m/min⁻¹)	487/1,600 (660/1,600)	
Displacement	cu in (L)	312.6 (5,123)	
Fuel Tank	US gal (L)	106.5 (403)	
DEF/AdBlue Tank	US gal (L)	21.9 (83)	
<b>HYDRAULIC SYSTEM</b>			
Pump	Two variable displacement pumps + one gear pump		
Max. Discharge Flow	US gpm (L/min)	64.7 (245) x 2 (main), 5.5 (21) x 1 (gear)	
Relief Valve Setting (main)/(Power Boost)	psi (MPa)	4,970 (34.3)/ {5,480 (37.8)}	
Swing Motor	Axial piston motor		
Travel Motors	2 x axial-piston, two-step motors		
Hydraulic Oil Tank (system)	US gal (L)	43.6 (165)/72.1 (273)	

\*Power Boost engaged

# Working Ranges

Unit: ft-in (m)

	SK260LC High & Wide Spec.	
Boom	19' 9" (6.02)	
Arm length	Std.: 9' 9" (2.98)	Long: 12' (3.66)
a- Max. digging reach	33' 10" (10.30)	36' (10.98)
b- Max. digging reach at ground level	33' (10.07)	35' 4" (10.76)
c- Max. digging depth	21' 10" (6.66)	24' 1" (7.34)
d- Max. digging height	33' 3" (10.13)	34' 8" (10.56)
e- Max. dumping clearance	23' 8" (7.22)	25' (7.62)
f- Min. dumping clearance	9' 6" (2.89)	7' 3" (2.21)
g- Max. vertical wall digging depth	19' 1" (5.81)	21' 8" (6.61)
h- Min. swing radius	12' 10" (3.91)	12' 10" (3.92)
i- Horizontal digging stroke at ground level	17' 5" (5.31)	21' 5" (6.54)
j- Digging depth for 8' (2.4 m) flat bottom	21' 3" (6.48)	23' 7" (7.20)
Bucket capacity (SAE heaped)	1.31 cu yd (1.0 m³)	1.06 cu yd (0.81 m³)

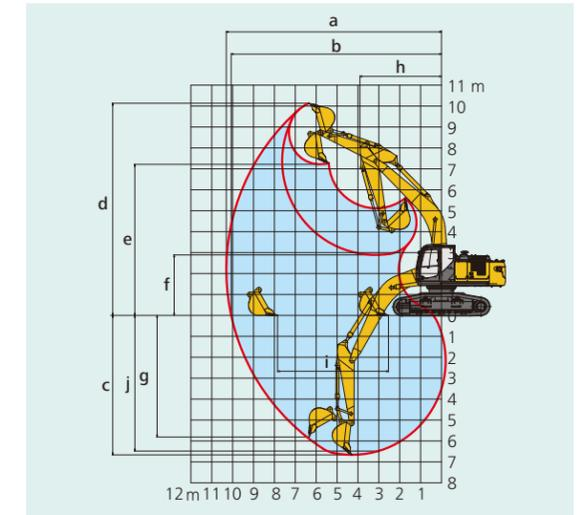

# General Dimensions

	SK260LC High & Wide Spec.	
Arm length	9' 9" (2,980)	12' (3,660)
A Overall length	33' 1" (10,090)	33' 2" (10,110)
B Overall height (to top of boom)	10' 10" (3,310)	11' (3,360)
C Overall width	11' 8" (3,550)	
D Overall height (to top of cab)	11' 3" (3,440)	
E Ground clearance of rear end*	4' 8" (1,430)	
F Ground clearance*	2' 7" (780)	

	Unit: ft-in (mm)	
G Tail swing radius	10' 2" (3,100)	
G' Distance from center of swing to rear end	10' 1" (3,070)	
H Tumbler distance	12' 5" (3,790)	
I Overall length of crawler	15' 3" (4,660)	
J Track gauge	9' 4" (2,850)	
K Shoe Width	28" (700)	
L Overall width of upperstructure	10' 3" (3,120)	

\*Without including height of shoe lug.

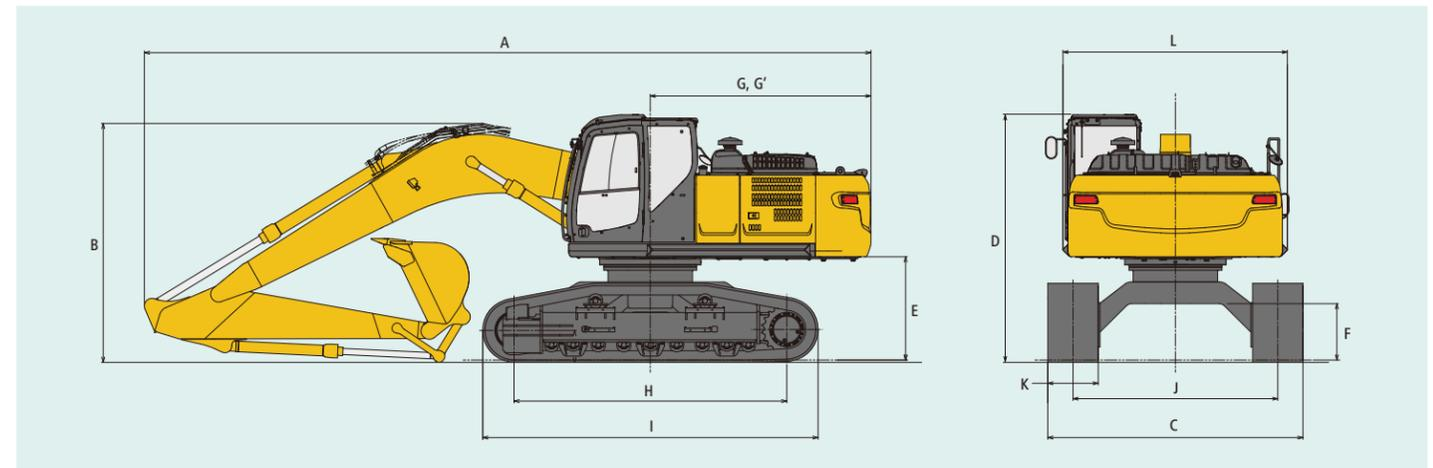

# Lifting Capacities

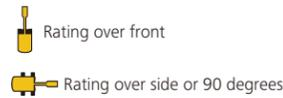
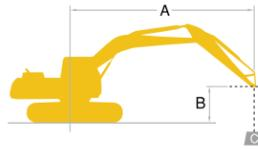

A – Reach from swing centerline to arm tip  
 B – Arm bucket pin height above/below ground  
 C – Lifting capacities in pounds (kilograms)  
 Relief valve setting: 5,480 psi

SK260LC		Standard Arm: 9' 9" (2.98 m) Without bucket Shoe: 28" (700 mm)										Radius		
B \ A		5' (1.5 m)		10' (3.0 m)		15' (4.6 m)		20' (6.1 m)		25' (7.6 m)		At. Max. reach		
25' (7.6 m)	lb (kg)											*10,790 (4,890)	*10,790 (4,890)	22' 7" (6.89 m)
20' (6.1 m)	lb (kg)							*13,070 (5,920)	*13,070 (5,920)	*13,090 (5,930)	12,970 (5,880)	*10,290 (4,660)	*10,290 (4,660)	25' 9" (7.86 m)
15' (4.6 m)	lb (kg)					*17,700 (8,020)	*17,700 (8,020)	*14,940 (6,770)	*14,940 (6,770)	*13,720 (6,220)	12,720 (5,760)	*10,270 (4,650)	*10,270 (4,650)	27' 9" (8.46 m)
10' (3.0 m)	lb (kg)					*23,030 (10,440)	*23,030 (10,440)	*17,460 (7,910)	*17,090 (7,750)	*14,930 (6,770)	12,320 (5,580)	*10,640 (4,820)	9,990 (4,530)	28' 8" (8.74 m)
5' (1.5 m)	lb (kg)					*27,390 (12,420)	24,690 (11,190)	*19,850 (9,000)	16,320 (7,400)	16,000 (7,250)	11,920 (5,400)	*11,430 (5,180)	9,770 (4,430)	28' 9" (8.76 m)
G. L.	lb (kg)			*16,450 (7,460)	*16,450 (7,460)	*29,470 (13,360)	24,000 (10,880)	*21,450 (9,720)	15,830 (7,180)	15,710 (7,120)	11,660 (5,280)	*12,830 (5,810)	10,060 (4,560)	27' 10" (8.50 m)
-5' (-1.5 m)	lb (kg)	*19,470 (8,830)	*19,470 (8,830)	*29,500 (13,380)	*29,500 (13,380)	*29,530 (13,390)	23,890 (10,830)	21,570 (9,780)	15,670 (7,100)	15,670 (7,100)	11,600 (5,260)	14,800 (6,710)	11,000 (4,980)	26' 0" (7.94 m)
-10' (-3.0 m)	lb (kg)	*32,390 (14,690)	*32,390 (14,690)	*39,160 (17,760)	*39,160 (17,760)	*27,660 (12,540)	24,180 (10,960)	*20,630 (9,350)	15,850 (7,180)			*17,180 (7,790)	13,170 (5,970)	23' 0" (7.01 m)
-15' (-4.6 m)	lb (kg)			*31,650 (14,350)	*31,650 (14,350)	*22,660 (10,270)						*17,970 (8,150)	*17,970 (8,150)	18' 1" (5.52 m)

SK260LC		Long Arm: 12' 0" (3.66 m) Without bucket Shoe: 28" (700 mm)										Radius				
B \ A		5' (1.5 m)		10' (3.0 m)		15' (4.6 m)		20' (6.1 m)		25' (7.6 m)		30' (9.1 m)		At. Max. reach		
30' (9.1 m)	lb (kg)													*8,830 (4,000)	*8,830 (4,000)	20' 10" (6.37 m)
25' (7.6 m)	lb (kg)									*8,890 (4,030)	*8,890 (4,030)			*7,910 (3,580)	*7,910 (3,580)	25' 4" (7.73 m)
20' (6.1 m)	lb (kg)									*11,430 (5,180)	*11,430 (5,180)			*7,550 (3,420)	*7,550 (3,420)	28' 3" (8.61 m)
15' (4.6 m)	lb (kg)							*13,170 (5,970)	*13,170 (5,970)	*12,320 (5,580)	*12,320 (5,580)	*7,670 (3,470)	*7,670 (3,470)	*7,510 (3,400)	*7,510 (3,400)	30' 0" (9.15 m)
10' (3.0 m)	lb (kg)			*31,420 (14,250)	*31,420 (14,250)	*20,310 (9,210)	*20,310 (9,210)	*15,840 (7,180)	*15,840 (7,180)	*13,720 (6,220)	12,340 (5,590)	*10,860 (4,920)	9,300 (4,210)	*7,710 (3,490)	*7,710 (3,490)	30' 11" (9.42 m)
5' (1.5 m)	lb (kg)			*13,380 (6,060)	*13,380 (6,060)	*25,340 (11,490)	25,020 (11,340)	*18,530 (8,400)	16,390 (7,430)	*15,220 (6,900)	11,880 (5,380)	*12,010 (5,440)	9,080 (4,110)	*8,190 (3,710)	*8,190 (3,710)	30' 11" (9.43 m)
G. L.	lb (kg)			*17,670 (8,010)	*17,670 (8,010)	*28,410 (12,880)	23,980 (10,870)	*20,570 (9,330)	15,760 (7,140)	15,580 (7,060)	11,520 (5,220)	*9,980 (4,520)	8,930 (4,050)	*9,020 (4,090)	8,850 (4,010)	30' 2" (9.19 m)
-5' (-1.5 m)	lb (kg)	*16,600 (7,520)	*16,600 (7,520)	*26,220 (11,890)	*26,220 (11,890)	*29,420 (13,340)	23,610 (10,700)	21,350 (9,680)	15,450 (6,980)	15,390 (6,980)	11,340 (5,140)			*10,460 (4,740)	9,540 (4,320)	28' 6" (8.68 m)
-10' (-3.0 m)	lb (kg)	*26,160 (11,860)	*26,160 (11,860)	*38,490 (17,450)	*38,490 (17,450)	*28,530 (12,940)	23,710 (10,750)	*21,160 (9,590)	15,470 (7,010)	15,500 (7,030)	11,440 (5,180)			*13,150 (5,960)	11,030 (5,000)	25' 8" (7.84 m)
-15' (-4.6 m)	lb (kg)			*36,000 (16,320)	*36,000 (16,320)	*25,210 (11,430)	24,260 (10,000)	*18,350 (8,320)	15,900 (7,210)					*16,390 (7,430)	14,460 (6,550)	21' 6" (6.55 m)

- Notes:
- Do not attempt to lift or hold any load that is greater than these lifting capacities at their specified lift point radius and heights. Weight of all accessories must be deducted from the above lifting capacities.
  - Lifting capacities are based on machine standing on level, firm, and uniform ground. User must make allowance for job conditions such as soft or uneven ground, out of level conditions, side loads, sudden stopping of loads, hazardous conditions, experience of personnel, etc.
  - Arm bucket pin, without bucket is defined as lift point.
  - The above lifting capacities are in compliance with SAE J/ISO 10567. They do not exceed 87 % of hydraulic lifting capacity or 75 % of tipping load. Lifting capacities marked with an asterisk (\*) are limited by hydraulic capacity rather than tipping load.
  - Operator should be fully acquainted with the Operator's and Maintenance Instructions before operating this machine. Rules for safe operation of equipment should be adhered to at all times.
  - Lifting capacities apply to only machines as originally manufactured and normally equipped by KOBELCO CONSTRUCTION MACHINERY CO., LTD.

# SK300LC

## Specifications

MODEL		SK300LC-10	
Specification		High & Wide	
<b>PERFORMANCE</b>			
Bucket Capacity (SAE heaped)	cu yd (m³)	1.57 (1.20)	
Swing Speed	rpm (min⁻¹)	10.2 (10.2)	
Swing Torque	lb-ft (kN-m)	72,700 (98.6)	
Travel Speed (high/low)	mph (km/h)	2.8/1.6 (4.5/2.6)	
Gradeability	% (degree)	70 (35)	
Bucket Digging Force	SAE lbf (kN)	37,300/41,100* (166/183*)	
	ISO lbf (kN)	42,300/46,800* (188/208*)	
Arm Crowding Force	SAE lbf (kN)	27,400/30,100* (122/134*)	
	ISO lbf (kN)	28,300/31,200* (126/139*)	
Drawbar Pulling Force	lbf (kN)	74,200 (330) (SAE J 1309)	
<b>WEIGHT</b>			
Operating Weight	lbs (kg)	73,600 (33,400)	
Ground Pressure	psi (kPa)	8.9 (61.5)	
Shoe Width	ft-in (mm)	28" (700)	
<b>ENGINE</b>			
Model	HINO J08EVV-KSDP		
Type	Direct injection, water-cooled, 4-cycle, 6-cylinder diesel engine with intercooler turbo-charger (Complies with EPA Tier IV Final)		
Power Output	(SAE NET) hp/rpm (kW/min⁻¹)	252/2,100 (188/2,100)	
	(Without fan) hp/rpm (kW/min⁻¹)	268/2,100 (200/2,100)	
Max. Torque	(SAE NET) lb-ft/rpm (N-m/min⁻¹)	729/1,600 (989/1,600)	
	(Without fan) lb-ft/rpm (N-m/min⁻¹)	750/1,600 (1,017/1,600)	
Displacement	cu in (L)	468.9 (7.684)	
Fuel Tank	US gal (L)	132.9 (503)	
DEF/AdBlue Tank	US gal (L)	21.9 (83)	
<b>HYDRAULIC SYSTEM</b>			
Pump	Two variable displacement pumps + one gear pump		
Max. Discharge Flow	US gpm (L/min)	65 (246) x 2 (main), 5.5 (21) x 1 (gear)	
Relief Valve Setting (main)/(Power Boost)	psi (MPa)	4,970 (34.3)/ {5,480 (37.8)}	
Swing Motor	Axial piston motor		
Travel Motors	2 x axial-piston, two-step motors		
Hydraulic Oil Tank (system)	US gal (L)	64.7 (245)/108.3 (410)	

\*Power Boost engaged

## Working Ranges

Unit: ft-in (m)

	SK300LC High & Wide Spec.	
Boom	20' 4" (6.2)	
Arm length	Std.: 10' 2" (3.10)	Long: 13' 1" (4.0)
a- Max. digging reach	35' 8" (10.87)	38' 5" (11.72)
b- Max. digging reach at ground level	34' 10" (10.61)	37' 8" (11.48)
c- Max. digging depth	22' 7" (6.89)	25' 7" (7.79)
d- Max. digging height	33' 10" (10.32)	35' 3" (10.74)
e- Max. dumping clearance	24' 4" (7.42)	25' 9" (7.84)
f- Min. dumping clearance	9' 5" (2.87)	6' 6" (1.97)
g- Max. vertical wall digging depth	19' 5" (5.91)	22' 3" (6.77)
h- Min. swing radius	14' 6" (4.43)	14' 11" (4.55)
i- Horizontal digging stroke at ground level	18' 6" (5.64)	23' 6" (7.17)
j- Digging depth for 8' (2.4 m) flat bottom	22' 1" (6.73)	25' 2" (7.66)
Bucket capacity (SAE heaped)	1.57 cu yd (1.2 m³)	1.57 cu yd (1.2 m³)

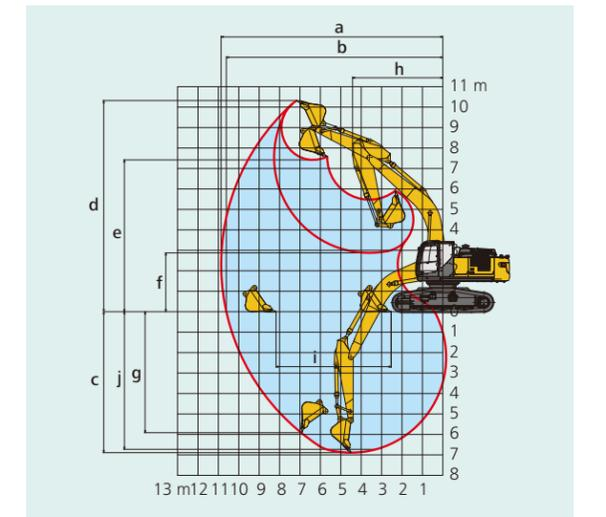

## General Dimensions

	SK300LC High & Wide Spec.	
Arm length	10' 2" (3,100)	13' 1" (4,000)
A Overall length	34' 10" (10,620)	35' (10,670)
B Overall height (to top of boom)	11' 4" (3,450)	11' 7" (3,520)
C Overall width	11' 11.5" (3,650)	
D Overall height (to top of cab)	11' 7" (3,530)	
E Ground clearance of rear end*	4' 11" (1,510)	
F Ground clearance*	2' 7" (785)	

	Unit: ft-in (mm)	
G Tail swing radius	10' 10" (3,300)	
G' Distance from center of swing to rear end	10' 9" (3,270)	
H Tumbler distance	13' 3" (4,050)	
I Overall length of crawler	16' 5" (5,010)	
J Track gauge	9' 8" (2,950)	
K Shoe Width	28" (700)	
L Overall width of upperstructure	10' 3" (3,120)	

\*Without including height of shoe lug.

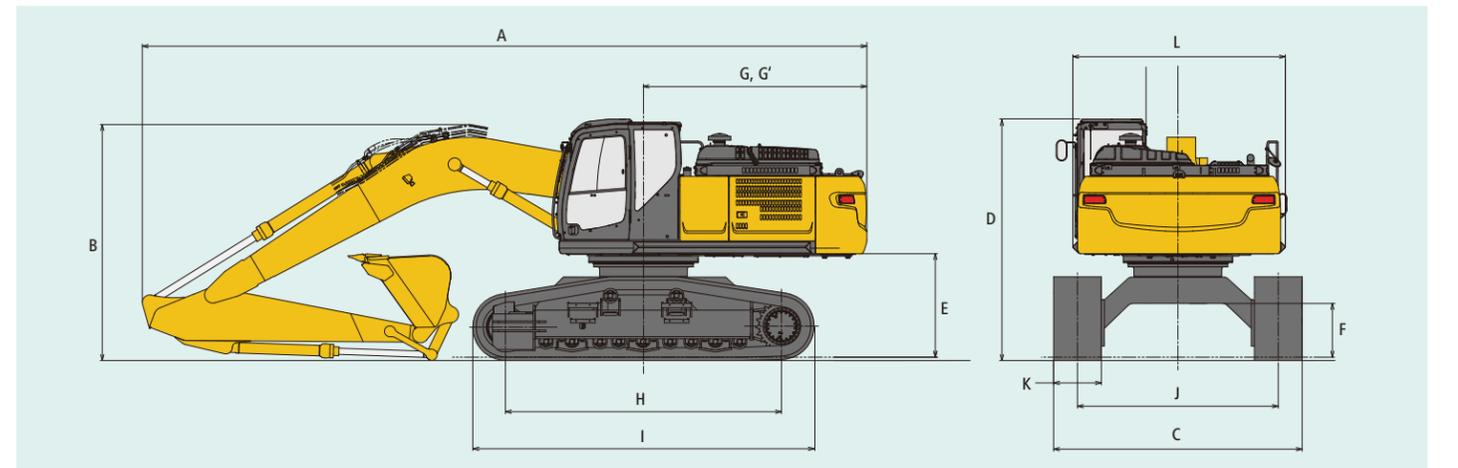

# Lifting Capacities

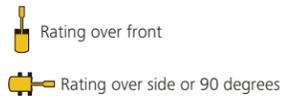
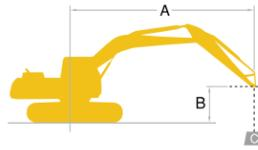

A – Reach from swing centerline to arm tip  
 B – Arm bucket pin height above/below ground  
 C – Lifting capacities in pounds (kilograms)  
 Relief valve setting: 5,480 psi

SK300LC		Standard Arm: 10' 2" (3.1 m) Without bucket Shoe: 28" (700 mm)														
B	A	5' (1.5 m)		10' (3.0 m)		15' (4.6 m)		20' (6.1 m)		25' (7.6 m)		30' (9.1 m)		At. Max. reach		Radius
		Rating over front	Rating over side or 90 degrees	Rating over front	Rating over side or 90 degrees	Rating over front	Rating over side or 90 degrees	Rating over front	Rating over side or 90 degrees	Rating over front	Rating over side or 90 degrees	Rating over front	Rating over side or 90 degrees	Rating over front	Rating over side or 90 degrees	
25' (7.6 m)	lb (kg)													*9,420 (4,270)	*9,420 (4,270)	24' 11" (7.60 m)
20' (6.1 m)	lb (kg)									*14,360 (6,510)	*14,360 (6,510)			*9,000 (4,080)	*9,000 (4,080)	27' 10" (8.48 m)
15' (4.6 m)	lb (kg)					*21,060 (9,550)	*21,060 (9,550)	*17,250 (7,820)	*17,250 (7,820)	*15,540 (7,040)	15,230 (6,900)			*8,970 (4,060)	*8,970 (4,060)	29' 7" (9.02 m)
10' (3.0 m)	lb (kg)					*28,060 (12,720)	*28,060 (12,720)	*20,560 (9,320)	20,350 (9,230)	*17,250 (7,820)	14,730 (6,680)	*12,040 (5,460)	11,240 (5,090)	*9,240 (4,190)	*9,240 (4,190)	30' 5" (9.27 m)
5' (1.5 m)	lb (kg)					*33,330 (15,110)	29,560 (13,400)	*23,590 (10,700)	19,490 (8,840)	*18,960 (8,600)	14,270 (6,470)	*12,770 (5,790)	11,040 (5,000)	*9,860 (4,470)	*9,860 (4,470)	30' 4" (9.25 m)
G. L.	lb (kg)			*16,280 (7,380)	*16,280 (7,380)	*35,620 (16,150)	28,920 (13,110)	*25,570 (11,590)	18,970 (8,600)	19,620 (8,890)	13,950 (6,320)			*10,950 (4,960)	*10,950 (4,960)	29' 5" (8.98 m)
-5' (-1.5 m)	lb (kg)	*21,220 (9,620)	*21,220 (9,620)	*29,370 (13,320)	*29,370 (13,320)	*35,650 (16,170)	28,850 (13,080)	*26,190 (11,870)	18,800 (8,520)	19,520 (8,850)	13,860 (6,280)			*12,880 (5,840)	12,220 (5,530)	27' 7" (8.42 m)
-10' (-3.0 m)	lb (kg)			*45,520 (20,640)	*45,520 (20,640)	*33,630 (15,250)	29,170 (13,230)	*25,060 (11,360)	18,970 (8,600)					*16,700 (7,570)	14,400 (6,530)	24' 7" (7.50 m)
-15' (-4.6 m)	lb (kg)			*39,960 (18,120)	*39,960 (18,120)	*28,430 (12,890)	*28,430 (12,890)							*20,250 (9,180)	19,870 (9,010)	19' 10" (6.05 m)

SK300LC		Long Arm: 13' 1" (4.0 m) Without bucket Shoe: 28" (700 mm)														
B	A	5' (1.5 m)		10' (3.0 m)		15' (4.6 m)		20' (6.1 m)		25' (7.6 m)		30' (9.1 m)		At. Max. reach		Radius
		Rating over front	Rating over side or 90 degrees	Rating over front	Rating over side or 90 degrees	Rating over front	Rating over side or 90 degrees	Rating over front	Rating over side or 90 degrees	Rating over front	Rating over side or 90 degrees	Rating over front	Rating over side or 90 degrees	Rating over front	Rating over side or 90 degrees	
30' (9.1 m)	lb (kg)													*7,310 (3,310)	*7,310 (3,310)	24' 5" (7.44 m)
25' (7.6 m)	lb (kg)									*11,330 (5,130)	*11,330 (5,130)			*6,670 (3,020)	*6,670 (3,020)	28' 3" (8.62 m)
20' (6.1 m)	lb (kg)									*11,830 (5,360)	*11,830 (5,360)	*9,200 (4,170)	*9,200 (4,170)	*6,400 (2,900)	*6,400 (2,900)	30' 10" (9.41 m)
15' (4.6 m)	lb (kg)									*13,210 (5,990)	*13,210 (5,990)	*12,840 (5,820)	11,310 (5,130)	*6,370 (2,880)	*6,370 (2,880)	32' 5" (9.89 m)
10' (3.0 m)	lb (kg)					*23,080 (10,460)	*23,080 (10,460)	*17,640 (8,000)	*17,640 (8,000)	*15,100 (6,840)	14,570 (6,600)	*13,820 (6,260)	11,000 (4,980)	*6,530 (2,960)	*6,530 (2,960)	33' 2" (10.12 m)
5' (1.5 m)	lb (kg)			*13,730 (6,220)	*13,730 (6,220)	*29,410 (13,340)	*29,410 (13,340)	*21,060 (9,550)	19,270 (8,740)	*17,070 (7,740)	13,950 (6,320)	*14,930 (6,770)	10,680 (4,840)	*6,900 (3,120)	*6,900 (3,120)	33' 2" (10.11 m)
G. L.	lb (kg)			*18,100 (8,210)	*18,100 (8,210)	*33,290 (15,100)	28,260 (12,810)	*23,690 (10,740)	18,480 (8,380)	*18,730 (8,490)	13,490 (6,110)	14,710 (6,670)	10,430 (4,730)	*7,560 (3,420)	*7,560 (3,420)	32' 4" (9.86 m)
-5' (-1.5 m)	lb (kg)	*17,570 (7,960)	*17,570 (7,960)	*25,950 (11,770)	*25,950 (11,770)	*34,770 (15,770)	27,820 (12,610)	*25,130 (11,390)	18,090 (8,200)	18,900 (8,570)	13,230 (6,000)	*12,940 (5,860)	10,350 (4,690)	*8,660 (3,920)	*8,660 (3,920)	30' 8" (9.35 m)
-10' (-3.0 m)	lb (kg)	*26,150 (11,860)	*26,150 (11,860)	*36,600 (16,600)	*36,600 (16,600)	*34,190 (15,500)	27,920 (12,660)	*25,120 (11,390)	18,070 (8,190)	18,930 (8,580)	13,260 (6,010)			*10,630 (4,820)	*10,630 (4,820)	28' 0" (8.53 m)
-15' (-4.6 m)	lb (kg)	*36,760 (16,670)	*36,760 (16,670)	*45,530 (20,650)	*45,530 (20,650)	*31,180 (14,140)	28,490 (12,920)	*22,990 (10,420)	18,450 (8,360)					*14,910 (6,760)	14,480 (6,560)	23' 11" (7.30 m)
-20' (-6.1 m)	lb (kg)			*23,460 (10,640)	*23,460 (10,640)									*18,800 (8,520)	*18,800 (8,520)	17' 7" (5.37 m)

- Notes:
- Do not attempt to lift or hold any load that is greater than these lifting capacities at their specified lift point radius and heights. Weight of all accessories must be deducted from the above lifting capacities.
  - Lifting capacities are based on machine standing on level, firm, and uniform ground. User must make allowance for job conditions such as soft or uneven ground, out of level conditions, side loads, sudden stopping of loads, hazardous conditions, experience of personnel, etc.
  - Arm bucket pin, without bucket is defined as lift point.
  - The above lifting capacities are in compliance with SAE J1506. They do not exceed 87 % of hydraulic lifting capacity or 75 % of tipping load. Lifting capacities marked with an asterisk (\*) are limited by hydraulic capacity rather than tipping load.
  - Operator should be fully acquainted with the Operator's and Maintenance Instructions before operating this machine. Rules for safe operation of equipment should be adhered to at all times.
  - Lifting capacities apply to only machines as originally manufactured and normally equipped by KOBELCO CONSTRUCTION MACHINERY CO., LTD.

# Specifications

MODEL		SK350LC-10	
Specification		High & Wide	
<b>PERFORMANCE</b>			
Bucket Capacity (SAE heaped)	cu yd (m³)	1.83 (1.40)	
Swing Speed	rpm (min⁻¹)	10.0 (10.0)	
Swing Torque	lb-ft (kN-m)	88,500 (120)	
Travel Speed (high/low)	mph (km/h)	3.6/2.2 (5.8/3.6)	
Gradeability	% (degree)	70 (35)	
Bucket Digging Force	SAE lbf (kN)	45,900/50,600* (204/225*)	
	ISO lbf (kN)	51,000/56,200* (227/250*)	
Arm Crowding Force	SAE lbf (kN)	37,100/39,600* (160/176*)	
	ISO lbf (kN)	37,100/40,700* (165/181*)	
Drawbar Pulling Force	lbf (kN)	70,400 (313) (SAE J 1309)	
<b>WEIGHT</b>			
Operating Weight	lbs (kg)	87,700 (39,800)	
Ground Pressure	psi (kPa)	10.6 (73)	
Shoe Width	ft-in (mm)	28" (700)	
<b>ENGINE</b>			
Model	HINO J08EVV-KSDK		
Type	Direct injection, water-cooled, 4-cycle, 6-cylinder diesel engine with intercooler turbo-charger (Complies with EPA Tier IV Final)		
Power Output	SAE NET hp/rpm (kW/min⁻¹)	270/2,100 (201/2,100)	
	(Without fan) hp/rpm (kW/min⁻¹)	286/2,100 (213/2,100)	
Max. Torque	SAE NET lb-ft/rpm (N-m/min⁻¹)	729/1,600 (989/1,600)	
	(Without fan) lb-ft/rpm (N-m/min⁻¹)	750/1,600 (1,017/1,600)	
Displacement	cu in (L)	468.9 (7.684)	
Fuel Tank	US gal (L)	132.9 (503)	
DEF/AdBlue Tank	US gal (L)	21.9 (83)	
<b>HYDRAULIC SYSTEM</b>			
Pump	Two variable displacement pumps + one gear pump		
Max. Discharge Flow	US gpm (L/min)	77.7 (294) x 2 (main), 5.5 (21) x 1 (gear)	
Relief Valve Setting (main)/(Power Boost)	psi (MPa)	4,970 (34.3)/ {5,480 (37.8)}	
Swing Motor	Axial piston motor		
Travel Motors	2 x axial-piston, two-step motors		
Hydraulic Oil Tank (system)	US gal (L)	64.7 (245)/108.3 (410)	

\*Power Boost engaged

# Working Ranges

Unit: ft-in (m)

	SK350LC High & Wide Spec.	
Boom	21' 4" (6.5)	
Arm length	Std.: 10' 10" (3.30)	Long: 13' 7" (4.15)
a- Max. digging reach	36' 11" (11.26)	39' 3" (11.97)
b- Max. digging reach at ground level	36' 1" (11.00)	38' 6" (11.73)
c- Max. digging depth	23' 9" (7.24)	26' 7" (8.09)
d- Max. digging height	35' 9" (10.90)	36' 2" (11.02)
e- Max. dumping clearance	25' 2" (7.68)	25' 9" (7.85)
f- Min. dumping clearance	9' 8" (2.94)	6' 10" (2.09)
g- Max. vertical wall digging depth	20' 8" (6.29)	22' 9" (6.94)
h- Min. swing radius	14' 2" (4.31)	14' 6" (4.43)
i- Horizontal digging stroke at ground level	19' 3" (5.87)	23' 11" (7.28)
j- Digging depth for 8' (2.4 m) flat bottom	23' 3" (7.08)	26' 1" (7.95)
Bucket capacity (SAE heaped)	1.83 cu yd (1.4 m³)	1.57 cu yd (1.2 m³)

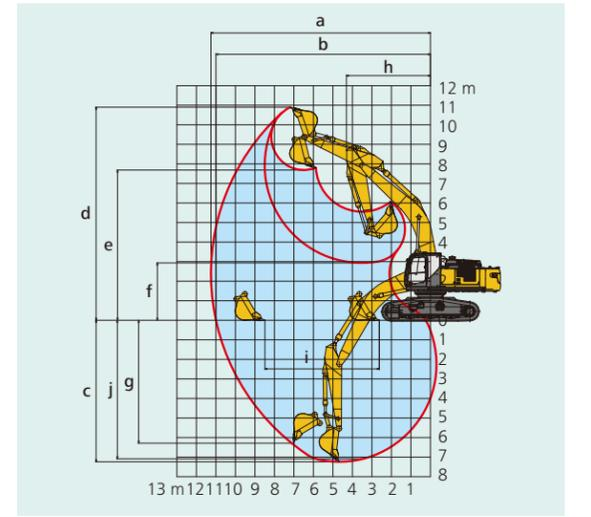

# General Dimensions

	SK350LC High & Wide Spec.	
Arm length	10' 10" (3,300)	13' 7" (4,150)
A Overall length	36' 8" (11,170)	36' 9" (11,200)
B Overall height (to top of boom)	11' 7" (3,530)	11' 4" (3,450)
C Overall width	11' 11.5" (3,650)	
D Overall height (to top of cab)	11' 7" (3,530)	
E Ground clearance of rear end*	4' 11" (1,510)	
F Ground clearance*	2' 7" (785)	

	Unit: ft-in (mm)	
G Tail swing radius	11' 10" (3,600)	
G' Distance from center of swing to rear end	11' 10" (3,600)	
H Tumbler distance	13' 3" (4,050)	
I Overall length of crawler	16' 5" (5,010)	
J Track gauge	9' 8" (2,950)	
K Shoe Width	28" (700)	
L Overall width of upperstructure	10' 3" (3,120)	

\*Without including height of shoe lug.

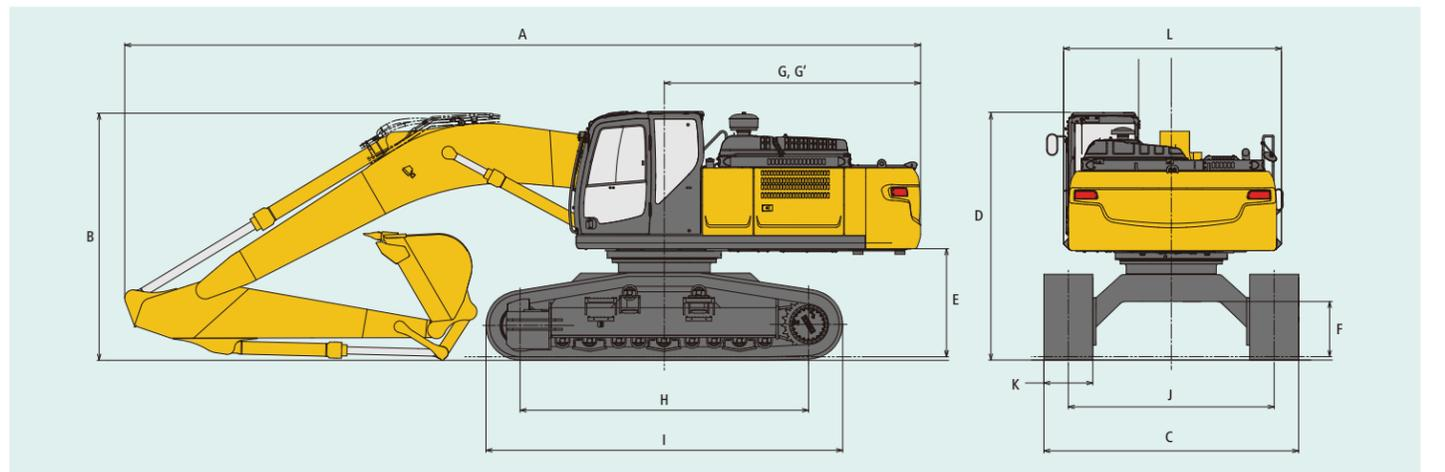

# Lifting Capacities

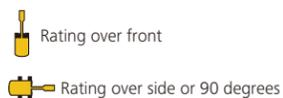
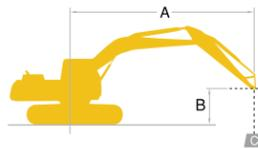

A – Reach from swing centerline to arm tip  
 B – Arm bucket pin height above/below ground  
 C – Lifting capacities in pounds (kilograms)  
 Relief valve setting: 5,480 psi

SK350LC		Standard Arm: 10' 10" (3.3 m) Without bucket						Shoe: 28" (700 mm)								
B	A	5' (1.5 m)		10' (3.0 m)		15' (4.6 m)		20' (6.1 m)		25' (7.6 m)		30' (9.1 m)		At. Max. reach		Radius
		Rating over front	Rating over side or 90 degrees	Rating over front	Rating over side or 90 degrees	Rating over front	Rating over side or 90 degrees	Rating over front	Rating over side or 90 degrees	Rating over front	Rating over side or 90 degrees	Rating over front	Rating over side or 90 degrees	Rating over front	Rating over side or 90 degrees	
30' (9.1 m)	lb (kg)													*13,870 (6,290)	*13,870 (6,290)	22' 2" (6.76 m)
25' (7.6 m)	lb (kg)									*17,350 (7,860)	*17,350 (7,860)			*12,820 (5,810)	*12,820 (5,810)	26' 3" (8.01 m)
20' (6.1 m)	lb (kg)									*17,740 (8,040)	*17,740 (8,040)			*12,470 (5,650)	*12,470 (5,650)	28' 11" (8.82 m)
15' (4.6 m)	lb (kg)					*27,640 (12,530)	*27,640 (12,530)	*21,940 (9,950)	*21,940 (9,950)	*19,030 (8,630)	*19,030 (8,630)	*16,270 (7,370)	15,010 (6,800)	*12,560 (5,690)	*12,560 (5,690)	30' 6" (9.32 m)
10' (3.0 m)	lb (kg)					*34,150 (15,490)	*34,150 (15,490)	*25,090 (11,380)	*25,090 (11,380)	*20,660 (9,370)	19,200 (8,700)	*18,180 (8,240)	14,690 (6,660)	*13,040 (5,910)	*13,040 (5,910)	31' 3" (9.54 m)
5' (1.5 m)	lb (kg)					*38,440 (17,430)	38,310 (17,370)	*27,700 (12,560)	25,310 (11,480)	*22,120 (10,030)	18,550 (8,410)	*18,800 (8,520)	14,370 (6,510)	*13,970 (6,330)	13,570 (6,150)	31' 2" (9.52 m)
G. L.	lb (kg)			*22,590 (10,240)	*22,590 (10,240)	*39,620 (17,970)	37,440 (16,980)	*29,050 (13,170)	24,600 (11,150)	*22,950 (10,400)	18,110 (8,210)	*18,880 (8,560)	14,180 (6,430)	*15,550 (7,050)	13,970 (6,330)	30' 4" (9.24 m)
-5' (-1.5 m)	lb (kg)	*27,770 (12,590)	*27,770 (12,590)	*38,520 (17,470)	*38,520 (17,470)	*38,410 (17,420)	37,340 (16,930)	*28,840 (13,080)	24,350 (11,040)	*22,650 (10,270)	17,950 (8,140)			*18,250 (8,270)	15,140 (6,860)	28' 6" (8.69 m)
-10' (-3.0 m)	lb (kg)	*42,770 (19,400)	*42,770 (19,400)	*47,340 (21,470)	*47,340 (21,470)	*34,950 (15,850)	*34,950 (15,850)	*26,660 (12,090)	24,530 (11,120)	*20,250 (9,180)	18,190 (8,250)			*19,350 (8,770)	17,640 (8,000)	25' 7" (7.81 m)
-15' (-4.6 m)	lb (kg)			*36,980 (16,770)	*36,980 (16,770)	*28,160 (12,770)	*28,160 (12,770)	*20,830 (9,440)						*18,840 (8,540)	*18,840 (8,540)	21' 2" (6.46 m)

SK350LC		Long Arm: 13' 7" (4.15 m) Without bucket						Shoe: 28" (700 mm)									
B	A	5' (1.5 m)		10' (3.0 m)		15' (4.6 m)		20' (6.1 m)		25' (7.6 m)		30' (9.1 m)		At. Max. reach		Radius	
		Rating over front	Rating over side or 90 degrees	Rating over front	Rating over side or 90 degrees	Rating over front	Rating over side or 90 degrees	Rating over front	Rating over side or 90 degrees	Rating over front	Rating over side or 90 degrees	Rating over front	Rating over side or 90 degrees	Rating over front	Rating over side or 90 degrees		
30' (9.1 m)	lb (kg)													*11,690 (5,300)	*11,690 (5,300)	25' 4" (7.74 m)	
25' (7.6 m)	lb (kg)																29' 0" (8.85 m)
20' (6.1 m)	lb (kg)																31' 5" (9.59 m)
15' (4.6 m)	lb (kg)																32' 11" (10.04 m)
10' (3.0 m)	lb (kg)																33' 7" (10.25 m)
5' (1.5 m)	lb (kg)																33' 7" (10.23 m)
G. L.	lb (kg)																32' 9" (9.98 m)
-5' (-1.5 m)	lb (kg)	*25,020 (11,340)	*25,020 (11,340)	*36,250 (16,440)	*36,250 (16,440)	*38,630 (17,520)	36,560 (16,580)	*28,470 (12,910)	23,820 (10,800)	*22,360 (10,140)	17,460 (7,910)	*18,130 (8,220)	13,660 (6,190)	*13,970 (6,330)	13,040 (5,910)	31' 1" (9.47 m)	
-10' (-3.0 m)	lb (kg)	*35,860 (16,260)	*35,860 (16,260)	*49,400 (22,400)	*49,400 (22,400)	*36,640 (16,610)	*36,640 (16,610)	*27,480 (12,460)	23,760 (10,770)	*21,410 (9,710)	17,450 (7,910)			*17,390 (7,880)	14,760 (6,690)	28' 5" (8.67 m)	
-15' (-4.6 m)	lb (kg)	*48,820 (22,140)	*48,820 (22,140)	*44,230 (20,060)	*44,230 (20,060)	*31,950 (14,490)	*31,950 (14,490)	*24,090 (10,920)						*18,160 (8,230)	*18,160 (8,230)	24' 6" (7.47 m)	
-20' (-6.1 m)	lb (kg)													*17,310 (7,850)	*17,310 (7,850)	18' 6" (5.64 m)	

- Notes:
- Do not attempt to lift or hold any load that is greater than these lifting capacities at their specified lift point radius and heights. Weight of all accessories must be deducted from the above lifting capacities.
  - Lifting capacities are based on machine standing on level, firm, and uniform ground. User must make allowance for job conditions such as soft or uneven ground, out of level conditions, side loads, sudden stopping of loads, hazardous conditions, experience of personnel, etc.
  - Arm bucket pin, without bucket is defined as lift point.
  - The above lifting capacities are in compliance with SAE J/ISO 10567. They do not exceed 87 % of hydraulic lifting capacity or 75 % of tipping load. Lifting capacities marked with an asterisk (\*) are limited by hydraulic capacity rather than tipping load.
  - Operator should be fully acquainted with the Operator's and Maintenance Instructions before operating this machine. Rules for safe operation of equipment should be adhered to at all times.
  - Lifting capacities apply to only machines as originally manufactured and normally equipped by KOBELCO CONSTRUCTION MACHINERY CO., LTD.

# SK500LC

## Specifications

MODEL		SK500LC-10	
Specification		High & Wide	
<b>PERFORMANCE</b>			
Bucket Capacity (SAE heaped)	cu yd (m <sup>3</sup> )	3.44 (2.64)	
Swing Speed	rpm (min <sup>-1</sup> )	7.6 (7.6)	
Swing Torque	lb-ft (kN-m)	134,980 [183.0] (SAE)	
Travel Speed (high/low)	mph (km/h)	3.4/2.1 (5.4/3.4)	
Gradeability	% (degree)	70 (35)	
Bucket Digging Force	SAE lbf (kN)	52,600/57,500* (234/256*)	
	ISO lbf (kN)	60,000/65,600* (267/292*)	
Arm Crowding Force	SAE lbf (kN)	43,800/48,100* (195/214*)	
	ISO lbf (kN)	45,600/49,900* (203/222*)	
Drawbar Pulling Force	lbf (kN)	92,700 (412) (SAE J 1349)	
<b>WEIGHT</b>			
Operating Weight	lbs (kg)	124,800 (56,600)	
Ground Pressure	psi (kPa)	10.6 (73)	
Shoe Width	ft-in (mm)	31.5" (800)	
<b>ENGINE</b>			
Model	HINO P11C-VN		
Type	Direct injection, water-cooled, 4-cycle, 6-cylinder diesel engine with intercooler turbo-charger (Complies with EPA Tier IV Final)		
Power Output (SAE NET)	hp/rpm (kW/min <sup>-1</sup> )	369/1,850 (271/1,850)	
Max. Torque (SAE NET)	lb-ft/rpm (N-m/min <sup>-1</sup> )	1,084/1,400 (1,470/1,400)	
Displacement	cu in (L)	642 (10.52)	
Fuel Tank	US gal (L)	169.1 (638)	
DEF/AdBlue Tank	US gal (L)	21.9 (83)	
<b>HYDRAULIC SYSTEM</b>			
Pump	Two variable displacement pumps + one gear pump		
Max. Discharge Flow	US gpm (L/min)	97.8 (370) x 2 (main), 16.8 (63.5) x 1 (gear)	
Relief Valve Setting (main)/(Power Boost)	psi (MPa)	4,550 (31.4)/(4,970 (34.3))	
Swing Motor	Axial piston motor		
Travel Motors	2 x axial-piston, two-step motors		
Hydraulic Oil Tank (system)	US gal (L)	98.0 (370.8)/166.7 (631)	

## Working Ranges

	SK500LC High & Wide Spec.		
	23' 0" (7.0)		
Boom	Standard: 11' 4" (3.45) / Semi-long: 13' 3" (4.04) / Long: 16' 1" (4.90)		
a- Max. digging reach	39' 7" (12.07)	41' 4" (12.61)	44' 3" (13.48)
b- Max. digging reach at ground level	38' 7" (11.77)	40' 5" (12.33)	43' 4" (13.22)
c- Max. digging depth	24' 6" (7.47)	26' 5" (8.06)	29' 3" (8.92)
d- Max. digging height	37' 0" (11.28)	37' 8" (11.48)	39' 6" (12.04)
e- Max. dumping clearance	26' 0" (7.92)	26' 8" (8.13)	28' 4" (8.64)
f- Min. dumping clearance	10' 3" (3.12)	8' 4" (2.53)	5' 6" (1.67)
g- Max. vertical wall digging depth	22' 3" (6.77)	23' 6" (7.16)	26' 5" (8.06)
h- Min. swing radius	16' 10" (5.14)	17' 1" (5.20)	17' 5" (5.31)
i- Horizontal digging stroke at ground level	20' 3" (6.16)	23' 5" (7.14)	27' 5" (8.36)
j- Digging depth for 8' (2.4 m) flat bottom	24' 0" (7.32)	26' 0" (7.93)	28' 10" (8.80)
Bucket capacity (SAE heaped)	3.44cu yd(2.64m <sup>3</sup> )	2.3cu yd(1.76m <sup>3</sup> )	2.0cu yd(1.53m <sup>3</sup> )

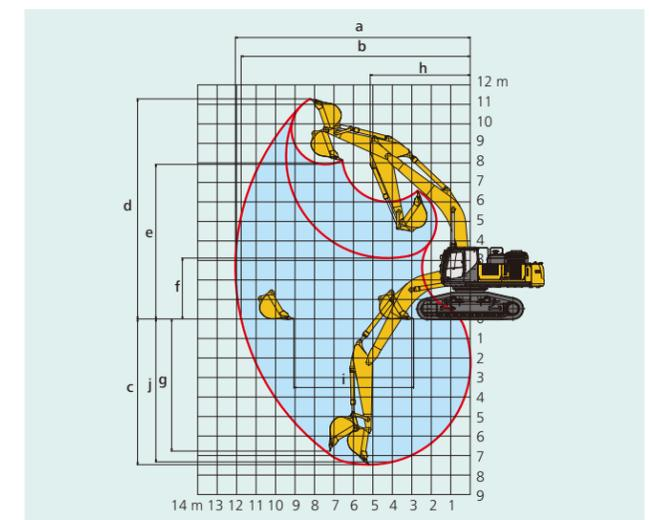

## General Dimensions

		SK500LC High & Wide Spec.		
Arm length		11' 4" (3,450)	13' 3" (4,040)	16' 1" (4,900)
A Overall length		39' 4" (12,000)	39' 6" (12,030)	40' 1" (12,220)
B Overall height (to top of boom)		12' (3,670)	12' 2" (3,720)	13' 10" (4,220)
C Crawler width (Extended/Retracted)		13' 2" (4,020) with step/11' 11.5" (3,650) without step		
C' Crawler width		13' (3,950)/11' 11.5" (3,650)		
D Overall height (to top of cab)		12' 3" (3,730)		
E Ground clearance of rear end*		5' 7" (1,690)		
F Ground clearance*		2' 10" (870)		

		Unit: ft-in (mm)
G Tail swing radius		12' 6" (3,800)
G' Distance from center of swing to rear end		12' 6" (3,800)
H Tumbler distance		14' 5" (4,400)
I Overall length of crawler		18' 0" (5,490)
J Track gauge (Extended/Retracted)		10' 6" (3,190)/9' 4" (2,850)
K Shoe Width		31.5" (800)
L Overall width of upperstructure		10' 2" (3,110)

\*Without including height of shoe lug.

