

KOBELCO

Hydraulic Excavator

SK75SR

SK75SR-7

SK85CS

SK85CS-7

Performance  Design

■ **Bucket Capacity:**

0.14 – 0.46 cu.yd. SAE

■ **Engine Power:**

70.0 hp {52.3 kW} @ 2,100 rpm
(SAE NET)

■ **Operating Weight:**

17,840 – 18,700 lbs
{8,090 – 8,490 kg}

SK75SR

19,270 – 20,100 lbs
{8,740 – 9,120 kg}

SK85CS



DRIVEN BY
PASSION

Complies with the latest exhaust emission regulations



US EPA
Tier IV Final



EU (NRMM)
Stage V



Japanese
Regulations





Performance  Design

PERFORMANCE BY DESIGN

The next generation of KOBELCO excavators bring together superior performance and thoughtful design like never before. Performance enhancements offer greater efficiency and productivity along with increased power and speed. Design improvements provide the ultimate in comfort and control.

KOBELCO refuses to compromise, creating machines that meet every challenge.

[View concept video](#)  

EXCEPTIONAL PERFORMANCE JUST GOT EVEN BETTER

KOBELCO engines comply with Tier IV emissions regulations

Low maintenance emissions. No DEF fluid required. Our latest machines offer even more power than previous models, significantly reducing cycle times. Our engines achieve high performance – maintaining both durability and efficiency even when working at high power levels, lifting heavy loads, or traveling on steep grades.

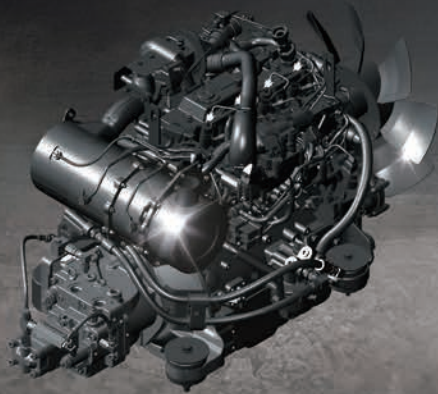

Model: YANMAR 4TNV98CT

Engine Output

Increased ~**28%**
(Compared to the previous size model)

Loaded Boom Lifting Speed

Increased ~**38%**
(Compared to the previous size model)

Digging Cycle Time

Reduced ~**15%**
(Compared to the previous size model)

Arm Digging Speed

Increased ~**37%**
(Compared to the previous size model)

Hill-Climbing Speed

Increased ~**22%**
(Compared to the previous size model)

Bucket Digging Force

14,070 lbs
{**62.6 kN**} (SAE)

Lifting Capacity

SK75SR **3,320 lbs** **27.2%** ↑
(Ground level over side @ 15')
(Compared to SK75SR-3E model)

SK85CS **3,570 lbs** **18.2%** ↑
(Ground level over side @ 15')
(Compared to SK85CS-3E model)



View machine in
operation



KOBELCO

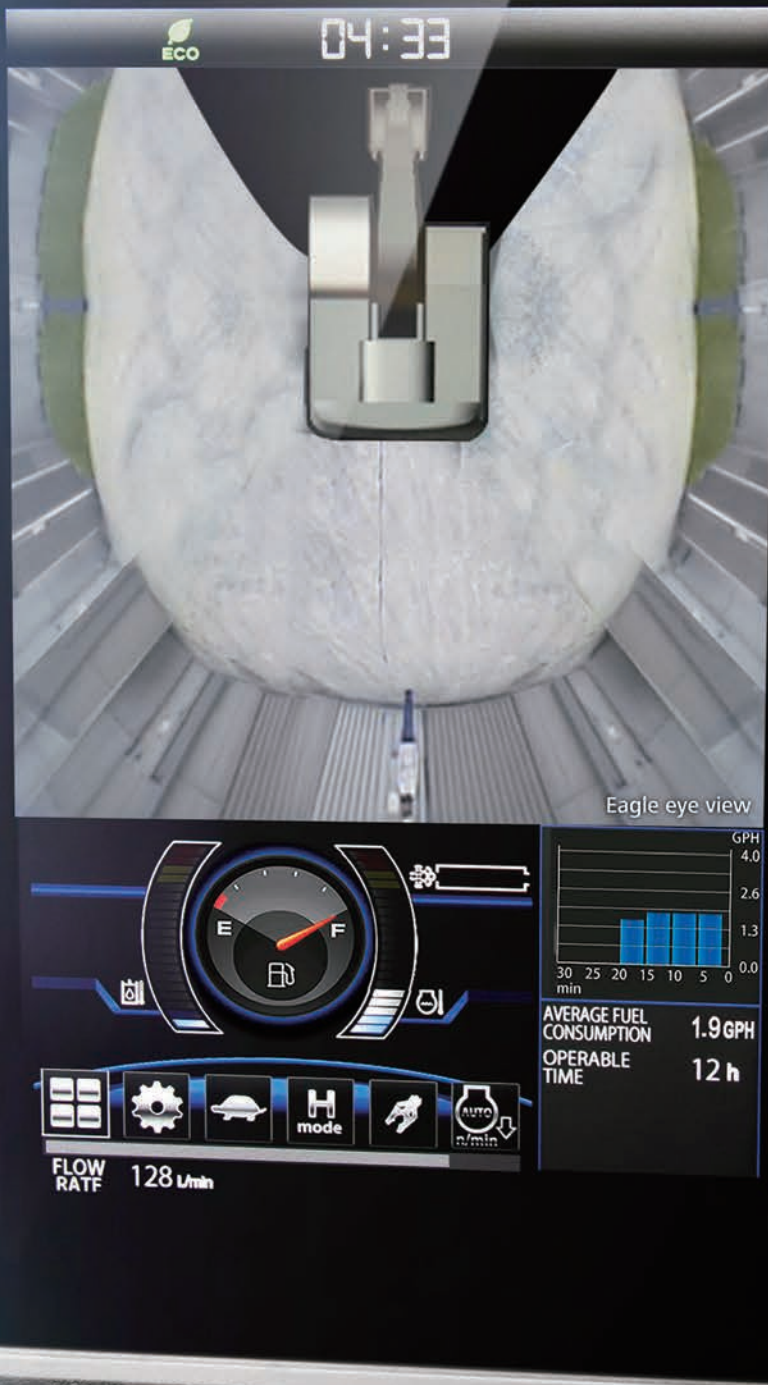

SAFETY ON FULL DISPLAY

Eagle Eye 3 Camera System

Our high-resolution, large display shows right, left and rear side camera together. Multiple display allows operator to customize viewing needs to enhance operator awareness and jobsite safety.



10-inch Color Monitor is the Largest in the Industry

The easy-to-operate menu screen and recognizable icons assist the operator to select the most important information needed to ensure jobsite safety and machine control.



Dial in the Right Information

Simply turn the jog dial to the right or left to select an operational feature, then press the dial to confirm selection.

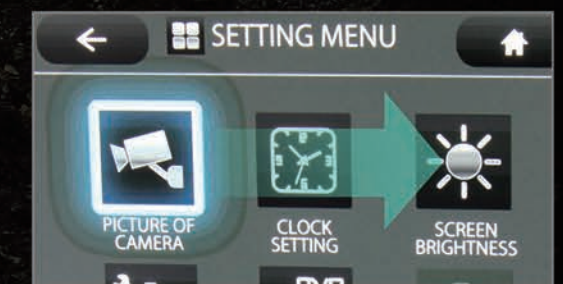

View the monitor in action





PREMIER OPERATOR COMFORTS

Air Ride Suspension Seat

A GRAMMER seat is offered as optional equipment, which achieves excellent shock absorption and superior ride comfort.

Multi Vent Air Conditioner

Cool air is blown from multiple outlets toward the operator's body for more comfortable operation.

Ergonomic Lever Angles

Operators can move levers horizontally without twisting their wrists, reducing fatigue.



Operating force is **25% reduced**
(Compared to the previous size model)

Adjustable Height Pilot Valves

Pilot valve height is manually adjustable to suit operator's preference. (Only for Optional Air ride Suspension Seat.)

LED Interior Light

Interior lights turn on and off automatically when the door is open or the ignition is turned to the OFF position. This ensures easy entry and exit in the dark.

Left Side Console

Flip up left console, with integrated pilot control lock lever, tilts for easy entry and exit from the cab.



View the interior
of the cab



THE ULTIMATE IN SIMPLE DESIGN

In our pursuit of functional beauty and styling, we created an all new interior design focused with the operator in mind.

Jog Dial

This dial integrates multiple functions into a single, easy to use interface. Even with gloves on, the operator can make the adjustments they need.

LED Illumination

Dials and buttons are now backlit to provide a bright, clear view in any lighting condition.



ENHANCED MULTI-FUNCTION CAPABILITIES

Attachment Mode Selection

The flow-rate modes for the bucket, breaker, nibbler and thumb are all adjustable presets, allowing you to change tools quickly and easily. Mode settings for other attachments like the tilt rotator can be added or changed.



EASY MAINTENANCE

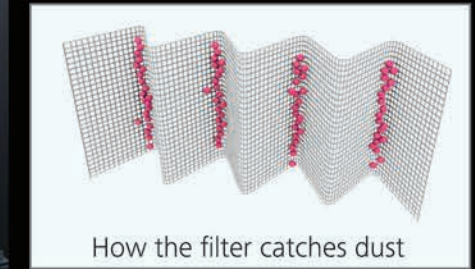
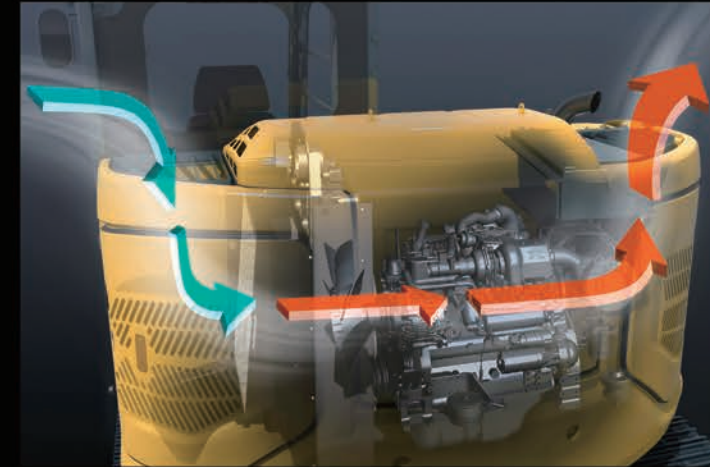

How the filter catches dust

iNDR

A high-density, stainless steel mesh filter, blocks debris from clogging the machine's coolers while promoting easy clean out without tools. The ridges of the corrugated filter allow the air to pass through, and the grooves collect the dust, which prevents the filter from clogging.

iNDR Filter

The corrugated design of the iNDR filter helps prevent the cooling system and air cleaner from clogging with dust while also reducing noise and maintenance to promote a cooler, more reliable hydraulics system and engine.



Standard FOPS overhead cab guard

The standard FOPS guard can be tilted open for easy window cleaning. Meets standard FOPS, Top Guard Level II requirements. (ISO10262)



Ground level storage compartment access

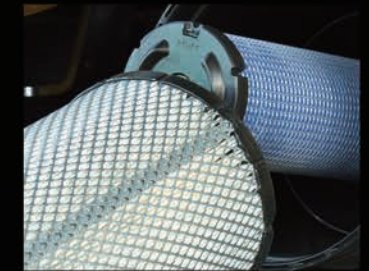

Two-stage air filter



Remote fuel tank drain valve



Easy-access oil drain valve



Ground level re-fueling

SAFETY AND CONVENIENCE IN EVERY CORNER



Standard built-in rear, left and right side cameras



Swing flashers for a safer job site



Travel alarm

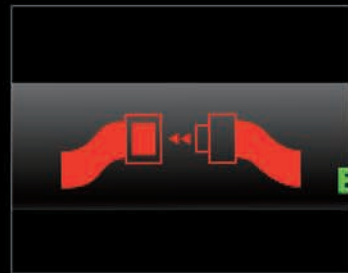

Seatbelt unfastened indicator



Standard LED lights
Bright LED lights ensure visibility even during night work



Optional front-guards (mesh or bar)



Increased clearance between the upper body and the track
For reduced damage from debris rolled upwards by the track during operation



Adjustable height pilot valves
Operator can adjust height of attachment control levers (Only for optional Air Ride Suspension Seat.)

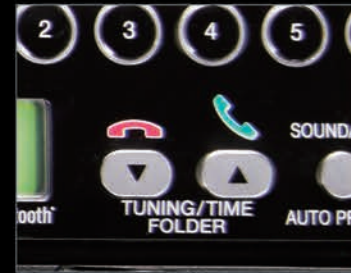

Hands-free phone calls



USB charging port / 12 V power socket



Smartphone holder
Includes USB port for charging



BS Geo Grip, bolt on rubber inserts



Easily removable bonnet



Ground level maintenance
iNDr filter

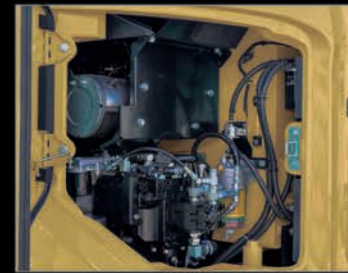

Ground level maintenance
Fuel filter / Fuel filter with built-in water-separator

Standard Equipment

SK75SR SK85CS
SK75SR-7 SK85CS-7

ENGINE

- Engine, YANMAR 4TNV98CT, Diesel engine with turbocharger and intercooler, Tier IV Final certified
- Auto Idle Stop
- Automatic engine deceleration
- Batteries (2 x 12 V - 72 Ah/781 A [CCA])
- Starting motor (24 V - 3.5 kW)
- 50 amp alternator
- Engine oil pan drain valve
- Two-stage air filter

CONTROL

- Working mode selector (H-mode, S-mode and ECO-mode)

SWING SYSTEM & TRAVEL SYSTEM

- Swing rebound prevention system
- Swing flasher
- Two-speed travel with automatic shift down
- Automatic travel priority
- Sealed & lubricated track links
- 23.6" (600 mm) steel track shoes, drilled for bolt on rubber inserts
- Grease-type track adjusters
- Automatic swing brake
- Dozer blade

MIRRORS, LIGHTS & CAMERAS

- Rear view mirrors, rear view camera and side view cameras
- Three LED front working lights

CAB & CONTROL

- Two control levers, pilot-operated
- Horn, electric
- Pattern changer
- LED door light (interior)
- Coat hook
- Large cup holder
- Detachable two-piece floor mat
- N&B hydraulic circuit
- Retractable 3-inch seatbelt
- Headrest
- Handrails
- Intermittent windshield wiper with double-spray washer
- Skylight
- Tilttable FOPS overhead cab guard (ISO 10262)
- Tinted safety glass
- Pull-type front window and removable lower front window
- Easy-to-read 10-inch LED SCREEN (Multi-display monitor)
- Automatic climate control
- Emergency escape hammer
- Radio (AUX & Bluetooth)
- 12 V converter
- Hands-free telephone
- USB charging port
- Travel alarm
- Lower swivel guard
- Dozer float function

Optional Equipment

- 17.7" (450 mm) Rubber tracks
- 17.7" (450 mm) BS Geo Grip
- 17.7" (450 mm) Steel track pads with bolt on rubber inserts
- Front-guard (mesh or bar)
- Cab additional light
- Offset boom (Only for SK75SR-7)

- Rotate hydraulic circuit
- Boom and arm hose burst valve
- Bolt on counterweight is available through parts department
- Air Ride Suspension seat

Note: Standard and optional equipment may vary. Consult your KOBELCO dealer for specifics.

Total Support for Machines with Network Speed and Accuracy



KOMEXS is a telematics system for receiving machine information. Manage your machines anywhere in the world using the Internet. Location, workload and diagnostic data aid business operations.

Direct Access to Operational Status

Location Data

Accurate location data can be obtained even from sites where communications are difficult.

Fuel Consumption Data

Data on fuel consumption and idling times can be used to indicate improvements in fuel consumption.

Operating Hours

A comparison of operating times of machines at multiple locations shows which locations are busier and more profitable. Operating hours on site can be accurately recorded, for running time calculations needed for rental machines, etc.

Graph of Work Content

The graph shows how working hours are divided among different operating categories, including digging, idling, traveling, and optional operations (NGB).

Maintenance Data and Warning Alerts

Machine Maintenance Data

Provides maintenance status of separate machines operating at multiple sites. Maintenance data is also relayed to KOBELCO service personnel, for more efficient planning of periodic servicing.

Security System

Engine Start Alarm
Sends a notification if the engine is started outside of pre-defined hours.

Area Alarm

Sends a notification if the machine leaves a pre-defined area.



Specifications

Engine

Model	YANMAR 4TNV98CT
Type	Four-stroke, liquid-cooled, direct injection diesel, turbo charged
No. of cylinders	4
Bore and stroke	3.86" x 4.33" (98 mm x 110 mm)
Displacement	202.5 cu.in (3.318 L)
Rated power output	70.0 hp {52.3 kW} /2,100 rpm (SAE NET) 72.0 hp {53.7 kW} /2,100 rpm (Without fan)
Max. torque	216 lb-ft {293 N·m} /1,365 rpm (SAE NET) 218 lb-ft {296 N·m} /1,365 rpm (Without fan)

Hydraulic System

Pump	
Type	Variable displacement piston pumps + one gear pump
Max. discharge flow	2 x 19.2 gpm (2 x 72.5 L/min) 1 x 5.0 gpm (1 x 19 L/min)
Relief valve setting	
Boom, arm and bucket	4,260 psi {29.4 MPa}
Travel circuit	4,260 psi {29.4 MPa}
Swing circuit	3,550 psi {24.5 MPa}
Control circuit	725 psi {5.0 MPa}
Pilot control pump	Gear type
Main control valves	12-spool
Oil cooler	Air cooled type

Swing System

Swing motor	One fixed displacement piston motor
Brake	Hydraulic; locking automatically when the swing control lever is in the neutral position
Parking brake	Wet multiple plate
Swing speed	11.5 rpm
Swing torque	12,500 lb-ft {17 kN·m}
Tail swing radius	4'6" {1,380 mm}

Hydraulic P.T.O.

Output Specification	Maximum Pressure PSI (Mpa)	Max. Flow US GPM, (lpm) (0 pressure)
		2,100 rpm
NGB	4,770 (32.9)	38 (145)
Rotary	3,130 (21.6)	12.7 (48)

Bucket Selection Chart

Bucket type	Bucket Capacity cu.yd. (SAE) (m³)	Bucket Width inches (m)	Bucket Weight lbs (kg)	Arm ft-in (m)
				7'0" (2.13 m)
Standard	0.14 {0.11}	16" {0.4}	330 {150}	H
Heavy Duty	0.18 {0.14}	16" {0.41}	350 {160}	H
	0.23 {0.18}	19" {0.48}	370 {170}	H
	0.29 {0.22}	23" {0.58}	420 {190}	H
	0.37 {0.28}	27" {0.68}	460 {210}	H

H – Used with material weight up to 3,000 lbs/cu.yd. (1,780 kg/m³)

Travel System

Travel motors	Variable displacement piston, two-speed motors
Travel brakes	Hydraulic brake
Parking brakes	Wet multiple plate
Travel shoes	39 each side
Travel speed	1.7/3.1 mph {2.7/5 km/h}
Drawbar pulling force	17,300 lbs {77 kN}
Gradeability	58% {30°}

Cab & Control

Cab	
All-weather, sound-suppressed steel cab mounted on silicon-sealed viscous mounts and equipped with a heavy, insulated floor mat	
Control	
Two hand levers and two foot pedals for travel	
Two hand levers for excavating and swing	
Electric rotary-type engine throttle	

Boom, Arm & Bucket

Boom cylinders	4.3" {110 mm} x 3' {916 mm}
Arm cylinder	3.7" {95 mm} x 2'9" {839 mm}
Bucket cylinder	3.3" {85 mm} x 2'6" {762 mm}

Dozer Blade

Dozer cylinder	5.3" {135 mm} x 5.1" {129 mm}
Dimension	8'0" {2,450 mm} (width) x 18" {460 mm} (height)
Working range	14" {360 mm} (up) x 10" {250 mm} (down)

Refilling Capacities & Lubrications

Fuel tank	31.7 U.S.gal {120 L}
Cooling system	3.4 U.S.gal {12.8 L}
Engine oil	3.1 U.S.gal {11.8 L}
Travel reduction gear	2 x 0.3 U.S.gal {1.3 L}
Swing reduction gear	0.4 U.S.gal {1.5 L}
Hydraulic oil tank	11.6 U.S.gal {44 L}: Tank oil level
	22.2 U.S.gal {84 L}: Hydraulic system

Working Ranges

Boom	12'6" {3.82 m}
Range	7'0" {2.13 m}
a-Max. digging reach	22'7" {6.88}
b-Max. digging reach at ground level	22'2" {6.76}
c-Max. digging depth	15'0" {4.58}
d-Max. digging height	25'5" {7.75}
e-Max. dumping clearance	18'7" {5.67}
f-Min. dumping clearance	7'2" {2.19}
g-Max. vertical wall digging depth	13'7" {4.14}
h-Min. swing radius	7'0" {2.13}
i-Horizontal digging stroke at ground level	10'6" {3.21}
j-Digging depth for 8' (2.4 m) flat bottom	14'2" {4.31}

Digging Force (ISO 6015)		
Unit: lbs {kN}		
Arm length	7'0" {2.13 m}	
Bucket digging force	SAE	14,070 {62.6}
	ISO	15,900 {70.9}
Arm crowding force	SAE	7,700 {34.2}
	ISO	7,900 {35.2}

Dimensions

Unit: ft-in (mm)	
Arm length	7'0" {2.13 m}
A Overall length	20'10" {6,360}
B Overall height (to top of boom)	8'4" {2,540}
C Overall width (23.6" {600 mm} shoes)	8'0" {2,450}
D Overall height (to top of cab)	8'5" {2,570}
E Ground clearance of rear end*	2'4" {720}
F Ground clearance*	14" {355}
G Tail swing radius	4'6" {1,380}
G' Distance from center of swing to rear end	4'6" {1,380}

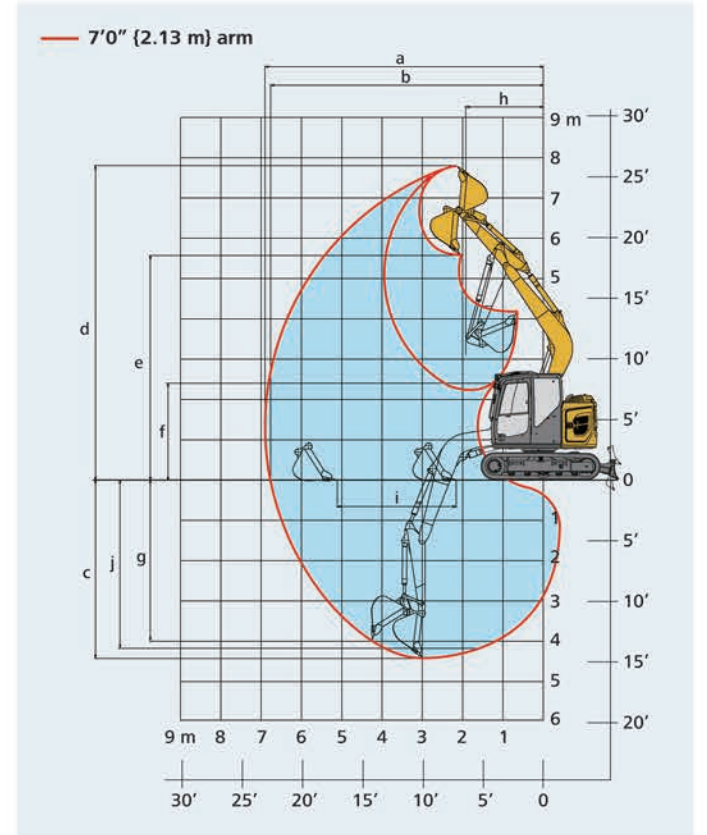

H Tumbler distance	7'3" {2,210}
I Overall length of crawler	9'3" {2,830}
J Track gauge	6'1" {1,850}
K Shoe width**	17.7" {450}/23.6" {600}
L Overall width of upperstructure	7'7" {2,300}

*Without including height of shoe lug **17.7" (450 mm) Rubber tracks, 23.6" (600 mm) Steel shoes

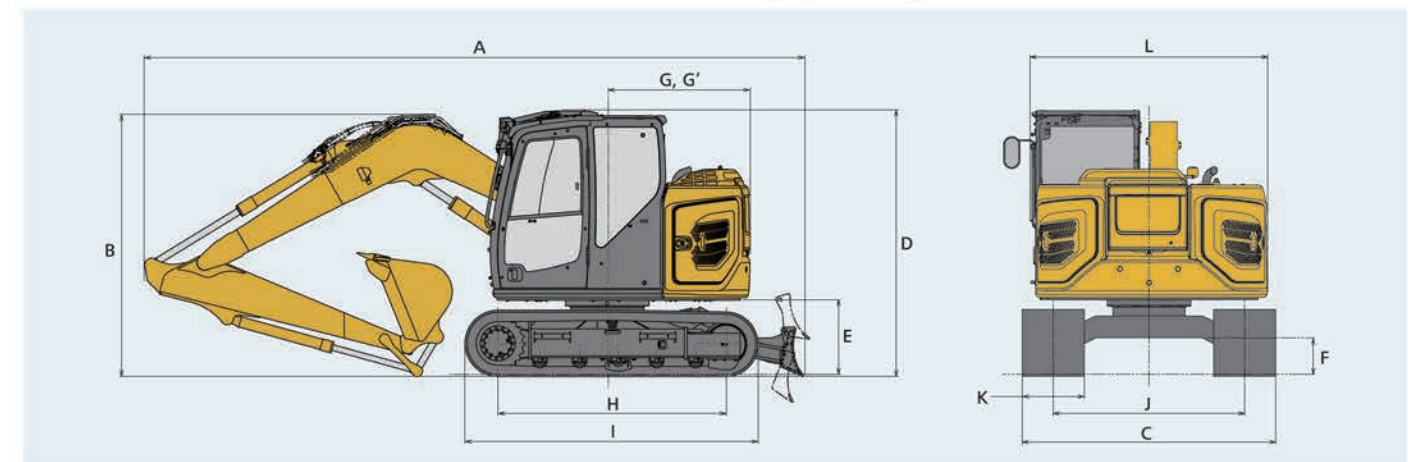

Operating Weight & Ground Pressure

In standard trim, with standard boom, 7'0" {2.13 m} arm, and 0.29 cu.yd. {0.22 m³} ISO heaped bucket

Shaped		Rubber tracks	Steel tracks
Shoe width	ft-in (mm)	17.7" {450}	23.6" {600}
Overall width of crawler	ft-in (mm)	7'7" {2,300}	8'0" {2,450}
Ground pressure	psi (kPa)	5.28 {36}	4.2 {29}
Operating weight	lbs (kg)	17,840 {8,090}	18,700 {8,490}

Offset Boom Specifications

SK75SR Offset Boom

SK75SR-7

Working Ranges

Unit: ft-in (m)

Range	Arm		
	12'6" (3.82 m)		
	5'9" (1.76 m)		
	Max. left	Center	Max. right
a-Max. digging reach	20'1" (6.11)	21'3" (6.48)	19'0" (5.78)
b-Max. digging reach at ground level	19'7" (5.97)	20'10" (6.34)	18'5" (5.62)
c-Max. digging depth	12'11" (3.94)	14'1" (4.30)	11'10" (3.60)
d-Max. digging height	23'6" (7.17)	24'7" (7.49)	22'7" (6.88)
e-Max. dumping clearance	16'9" (5.11)	17'10" (5.43)	15'9" (4.81)
f-Min. dumping clearance	7'0" (2.13)	8'0" (2.45)	6'0" (1.83)
g-Max. vertical wall digging depth	9'9" (2.96)	9'11" (3.30)	8'8" (2.64)
h-Min. swing radius	4'11" (1.49)	13'0" (1.21)	6'8" (2.04)
i-Horizontal digging stroke at ground level	10'2" (3.10)	10'1" (3.08)	10'2" (3.09)
j-Digging depth for 8' (2.4 m) flat bottom	11'8" (3.55)	12'10" (3.92)	10'6" (3.21)

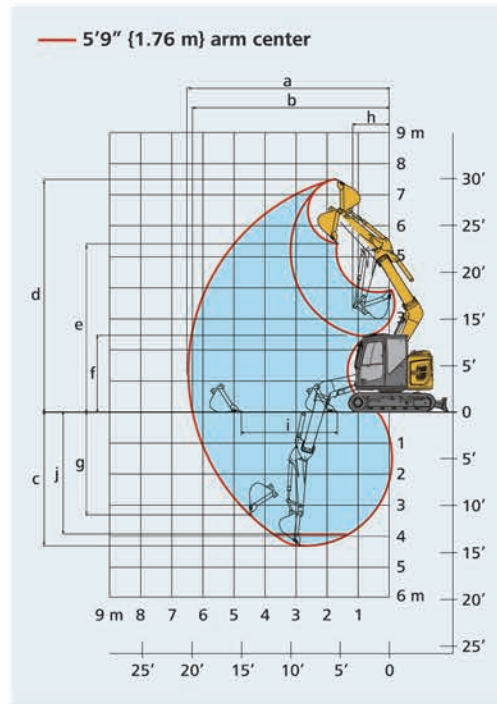

Digging Force (ISO 6015)

Unit: lbs (kN)

Arm length		5'9" (1.76 m)
Bucket digging force	SAE	14,070 (62.6)
	ISO	15,900 (70.9)
Arm crowding force	SAE	8,480 (37.7)
	ISO	8,860 (39.4)

Dimensions

Unit: ft-in (mm)

Arm length		5'9" (1.76 m)
A Overall length		20'3" (6,160)
B Overall height (to top of boom)		7'8" (2,330)
C Overall width (23.6" (600 mm) shoes)		8'0" (2,450)
D Overall height (to top of cab)		8'5" (2,570)
E Ground clearance of rear end*		2'4" (720)
F Ground clearance*		14" (355)
G Tail swing radius		4'6" (1,380)
G' Distance from center of swing to rear end		4'6" (1,380)
H Tumbler distance		7'3" (2,210)
I Overall length of crawler		9'3" (2,830)
J Track gauge		6'1" (1,850)
K Shoe width**		17.7" (450)/23.6" (600)
L Overall width of upperstructure		7'7" (2,300)

*Without including height of shoe lug **17.7" (450 mm) Rubber tracks, 23.6" (600 mm) Steel shoes

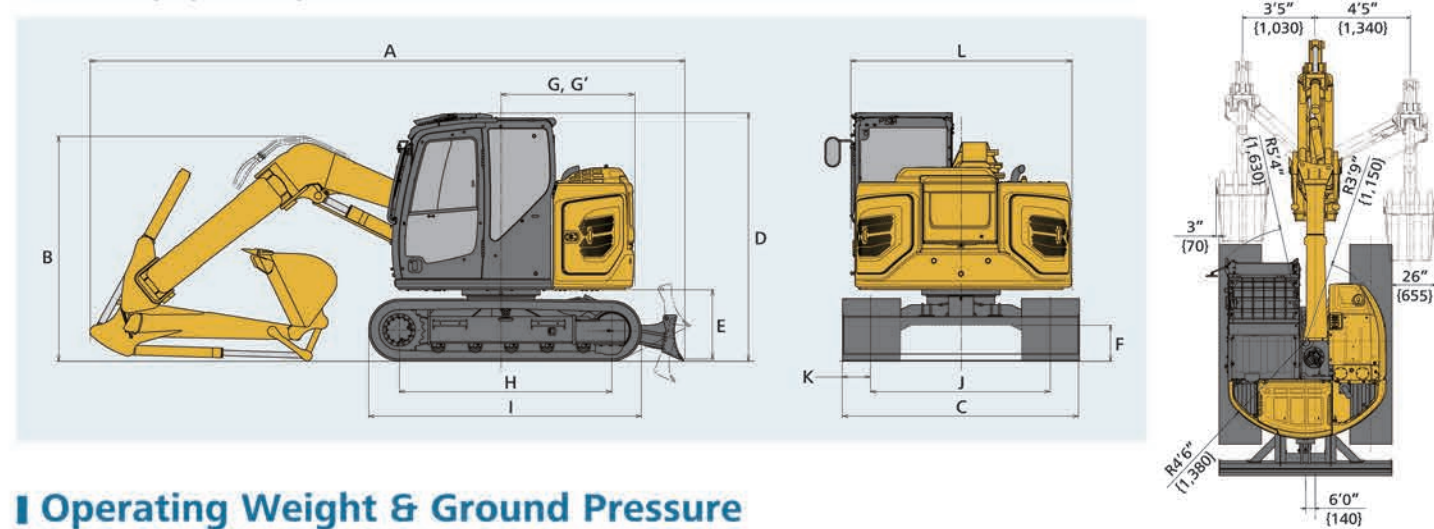

Operating Weight & Ground Pressure

In standard trim, with standard boom, 5'9" (1.76 m) arm, and 0.29 cu.yd. (0.22 m³) ISO heaped bucket

Shaped		Rubber tracks	Steel tracks
Shoe width	ft-in (mm)	17.7" (450)	23.6" (600)
Overall width of crawler	ft-in (mm)	7'7" (2,300)	8'0" (2,450)
Ground pressure	psi (kPa)	5.52 (38)	4.34 (30)
Operating weight	lbs (kg)	18,678 (8,470)	19,555 (8,870)

Lifting Capacities

SK75SR SK75SR Offset Boom

SK75SR-7 SK75SR-7



A - Reach from swing centerline
 B - Height above/below ground
 C - Lifting capacities in pounds (kg)
 Relief valve setting: 4,260 psi (29.4 MPa)

SK75SR		Arm: 7'0" (2.13 m) No bucket Standard counterweight		Shoe: 17.7" (450 mm) Rubber tracks		Dozer: blade down		Radius
A		5' (1.5 m)		10' (3.0 m)		15' (4.6 m)		
B		At max. reach		At max. reach		At max. reach		
20' (6.1 m)	lb (kg)			*5,020 (2,270)	*5,020 (2,270)			10'11" (3.34 m)
15' (4.6 m)	lb (kg)			*4,660 (2,110)	*4,660 (2,110)	*4,310 (1,950)	3,610 (1,630)	15'11" (4.85 m)
10' (3.0 m)	lb (kg)			*5,750 (2,600)	*5,750 (2,600)	*4,520 (2,050)	3,520 (1,590)	18'4" (5.59 m)
5' (1.5 m)	lb (kg)			*7,430 (3,370)	6,050 (2,740)	*5,000 (2,260)	3,320 (1,500)	19'2" (5.84 m)
G.L.	lb (kg)			*7,990 (3,620)	5,640 (2,550)	*5,190 (2,350)	3,160 (1,430)	18'7" (5.68 m)
-5' (-1.5 m)	lb (kg)	*7,340 (3,320)	*7,340 (3,320)	*7,000 (3,170)	5,560 (2,520)	*4,530 (2,050)	3,110 (1,410)	16'8" (5.08 m)
-10' (-3.0 m)	lb (kg)	*5,890 (2,670)	*5,890 (2,670)	*4,180 (1,890)	*4,180 (1,890)			12'6" (3.81 m)

SK75SR		Arm: 7'0" (2.13 m) No bucket Standard counterweight		Shoe: 23.6" (600 mm) Steel tracks		Dozer: blade down		Radius
A		5' (1.5 m)		10' (3.0 m)		15' (4.6 m)		
B		At max. reach		At max. reach		At max. reach		
20' (6.1 m)	lb (kg)			*5,020 (2,270)	*5,020 (2,270)			10'11" (3.34 m)
15' (4.6 m)	lb (kg)			*4,660 (2,110)	*4,660 (2,110)	*4,310 (1,950)	3,770 (1,710)	15'11" (4.85 m)
10' (3.0 m)	lb (kg)			*5,740 (2,600)	*5,740 (2,600)	*4,520 (2,050)	3,680 (1,660)	18'4" (5.59 m)
5' (1.5 m)	lb (kg)			*7,430 (3,370)	6,320 (2,860)	*5,000 (2,260)	3,480 (1,570)	19'2" (5.84 m)
G.L.	lb (kg)			*7,990 (3,620)	5,920 (2,680)	*5,190 (2,350)	3,320 (1,500)	18'8" (5.69 m)
-5' (-1.5 m)	lb (kg)	*7,340 (3,320)	*7,340 (3,320)	*7,000 (3,170)	5,830 (2,640)	*4,530 (2,050)	3,270 (1,480)	16'8" (5.08 m)
-10' (-3.0 m)	lb (kg)	*5,900 (2,670)	*5,900 (2,670)	*4,180 (1,890)	*4,180 (1,890)			12'6" (3.81 m)

SK75SR Offset		Arm: 5'9" (1.76 m) No bucket Standard counterweight		Shoe: 17.7" (450 mm) Rubber tracks		Dozer: blade down		Radius
A		5' (1.5 m)		10' (3.0 m)		15' (4.6 m)		
B		At max. reach		At max. reach		At max. reach		
20' (6.1 m)	lb (kg)							8'4" (2.56 m)
15' (4.6 m)	lb (kg)			*5,420 (2,450)	*5,420 (2,450)			14'3" (4.36 m)
10' (3.0 m)	lb (kg)			*6,480 (2,930)	6,460 (2,930)	*4,870 (2,200)	3,300 (1,490)	16'11" (5.16 m)
5' (1.5 m)	lb (kg)			*7,920 (3,590)	5,460 (2,470)	*5,240 (2,370)	3,010 (1,360)	17'10" (5.43 m)
G.L.	lb (kg)			*8,000 (3,620)	4,940 (2,240)	*5,250 (2,380)	2,780 (1,260)	17'3" (5.26 m)
-5' (-1.5 m)	lb (kg)	*8,470 (3,840)	*8,470 (3,840)	*6,630 (3,000)	4,910 (2,220)	*4,230 (1,910)	2,760 (1,250)	15'1" (4.61 m)
-10' (-3.0 m)	lb (kg)			*3,110 (1,410)	*3,110 (1,410)			10'4" (3.15 m)

SK75SR Offset		Arm: 5'9" (1.76 m) No bucket Standard counterweight		Shoe: 23.6" (600 mm) Steel tracks		Dozer: blade down		Radius
A		5' (1.5 m)		10' (3.0 m)		15' (4.6 m)		
B		At max. reach		At max. reach		At max. reach		
20' (6.1 m)	lb (kg)							8'4" (2.56 m)
15' (4.6 m)	lb (kg)			*5,420 (2,450)	*5,420 (2,450)			14'3" (4.35 m)
10' (3.0 m)	lb (kg)			*6,480 (2,930)	*6,480 (2,930)	*4,870 (2,200)	3,460 (1,560)	16'11" (5.16 m)
5' (1.5 m)	lb (kg)			*7,920 (3,590)	5,730 (2,590)	*5,240 (2,370)	3,170 (1,430)	17'10" (5.43 m)
G.L.	lb (kg)			*8,000 (3,620)	5,210 (2,360)	*5,250 (2,380)	2,940 (1,330)	17'3" (5.26 m)
-5' (-1.5 m)	lb (kg)	*8,470 (3,840)	*8,470 (3,840)	*6,630 (3,000)	5,180 (2,340)	*4,230 (1,910)	2,920 (1,320)	15'1" (4.61 m)
-10' (-3.0 m)	lb (kg)			*3,120 (1,410)	*3,120 (1,410)			10'4" (3.15 m)

Note:

- Do not attempt to lift or hold any load that is greater than these lift capacities at their specified lift point radius and heights. Weight of all accessories must be deducted from the above lift capacities.
- Lift capacities are based on machine standing on level, firm, and uniform ground. User must make allowance for job conditions such as soft or uneven ground, out of level conditions, side loads, sudden stopping of loads, hazardous conditions, experience of personnel, etc.
- Bucket pin attachment point defined as lift point.
- The above lifting capacities are in compliance with ISO 10567. They do not exceed 87% of hydraulic lifting capacity or 75% of tipping load. Lifting capacities marked with an asterisk(*) are limited by hydraulic capacity rather than tipping load.
- Operator should be fully acquainted with the Operator's and Maintenance Instructions before operating this machine. Rules for safe operation of equipment should be adhered to at all times.
- Lift capacities apply to only machine as originally manufactured and normally equipped by KOBELCO CONSTRUCTION MACHINERY CO., LTD.

Specifications

Engine

Model	YANMAR 4TNV98CT
Type	Four-stroke, liquid-cooled, direct injection diesel, turbo charged
No. of cylinders	4
Bore and stroke	3.86" x 4.33" (98 mm x 110 mm)
Displacement	202.5 cu.in (3.318 L)
Rated power output	70.0 hp (52.3 kW) /2,100 rpm (SAE NET) 72.0 hp (53.7 kW) /2,100 rpm (Without fan)
Max. torque	216 lb-ft (293 N·m) /1,365 rpm (SAE NET) 218 lb-ft (296 N·m) /1,365 rpm (Without fan)

Hydraulic System

Pump	
Type	Variable displacement piston pumps + one gear pump
Max. discharge flow	2 x 19.2 U.S.gpm (2 x 72.5 L/min) 1 x 5.0 U.S.gpm (1 x 19 L/min)
Relief valve setting	
Boom, arm and bucket	4,260 psi {29.4 MPa}
Travel circuit	4,260 psi {29.4 MPa}
Swing circuit	3,550 psi {24.5 MPa}
Control circuit	725 psi {5.0 MPa}
Pilot control pump	Gear type
Main control valves	13-spool
Oil cooler	Air cooled type

Swing System

Swing motor	One fixed displacement piston motor
Brake	Hydraulic; locking automatically when the swing control lever is in the neutral position
Parking brake	Wet multiple plate
Swing speed	11.5 rpm
Swing torque	12,500 lb-ft (17 kN·m)
Tail swing radius	5' 5" {1,650 mm}

Hydraulic P.T.O.

Output Specification	Maximum Pressure PSI (Mpa)	Max. Flow US GPM, (lpm) (0 pressure)
		2,100 rpm
NGB	4,770 (32.9)	38 (145)
Rotary	3,130 (21.6)	12.7 (48)

Bucket Selection Chart

Bucket type	Bucket Capacity cu.yd. (SAE) {m³}	Bucket Width inches {m}	Bucket Weight lbs {kg}	Arm ft-in (m)
				7'0" {2.13 m}
Standard	0.14 {0.11}	16" {0.4}	330 {150}	H
	0.18 {0.14}	16" {0.41}	350 {160}	H
Heavy Duty	0.23 {0.18}	19" {0.48}	370 {170}	H
	0.29 {0.22}	23" {0.58}	420 {190}	H
	0.37 {0.28}	27" {0.68}	460 {210}	H

H – Used with material weight up to 3,000 lbs/cu.yd. (1,780 kg/m³)

Travel System

Travel motors	Variable displacement piston, two-speed motors
Travel brakes	Hydraulic brake
Parking brakes	Wet multiple plate
Travel shoes	39 each side
Travel speed	1.7/3.1 mph {2.7/5 km/h}
Drawbar pulling force	17,200 lbs {77 kN}
Gradeability	58% {30°}

Cab & Control

Cab	
All-weather, sound-suppressed steel cab mounted on the silicon-sealed viscous mounts and equipped with a heavy, insulated floor mat	
Control	
Two hand levers and two foot pedals for travel	
Two hand levers for excavating and swing	
Electric rotary-type engine throttle	

Boom, Arm & Bucket

Boom cylinders	4.3" {110 mm} x 3' {916 mm}
Arm cylinder	3.7" {95 mm} x 2' 9" {839 mm}
Bucket cylinder	3.3" {85 mm} x 2' 6" {762 mm}

Dozer Blade

Dozer cylinder	5.7" {145 mm} x 7.4" {189 mm}
Dimension	8'0" {2,450 mm} (width) x 18" {460 mm} (height)
Working range	20" {500 mm} (up) x 20" {500 mm} (down)

Refilling Capacities & Lubrications

Fuel tank	31.7 U.S.gal {120 L}
Cooling system	3.4 U.S.gal {12.8 L}
Engine oil	3.1 U.S.gal {11.8 L}
Travel reduction gear	2 x 0.3 U.S.gal {1.3 L}
Swing reduction gear	0.4 U.S.gal {1.5 L}
Hydraulic oil tank	11.6 U.S.gal {44 L}: Tank oil level
	22.2 U.S.gal {84 L}: Hydraulic system

Working Ranges

Unit: ft-in {m}

Boom	11'6" {3.50 m}
Range	7'0" {2.13 m}
a- Max. digging reach	24'7" {7.50}
b- Max. digging reach at ground level	24'1" {7.34}
c- Max. digging depth	14'7" {4.44}
d- Max. digging height	23'9" {7.23}
e- Max. dumping clearance	17'0" {5.18}
f- Min. dumping clearance	5'7" {1.70}
g- Max. vertical wall digging depth	12'4" {3.75}
h- Min. swing radius	9'2" {2.80}
i- Horizontal digging stroke at ground level	11'6" {3.51}
j- Digging depth for 8' (2.4 m) flat bottom	13'5" {4.12}

Digging Force (ISO 6015)

Unit: lbs {kN}

Arm length	7'0" {2.13 m}	
Bucket digging force	SAE	14,070 {62.6}
	ISO	15,900 {70.9}
Arm crowding force	SAE	7,350 {32.7}
	ISO	7,580 {33.7}

Dimensions

Unit: ft-in {mm}

Arm length	7'0" {2.13 m}
A Overall length	22'2" {6,750}
B Overall height (to top of boom)	8'4" {2,550}
C Overall width (23.6" {600 mm} shoes)	8'0" {2,450}
D Overall height (to top of cab)	8'5" {2,570}
E Ground clearance of rear end*	2'4" {720}
F Ground clearance*	14" {355}
G Tail swing radius	5'5" {1,650}
G' Distance from center of swing to rear end	5'5" {1,650}

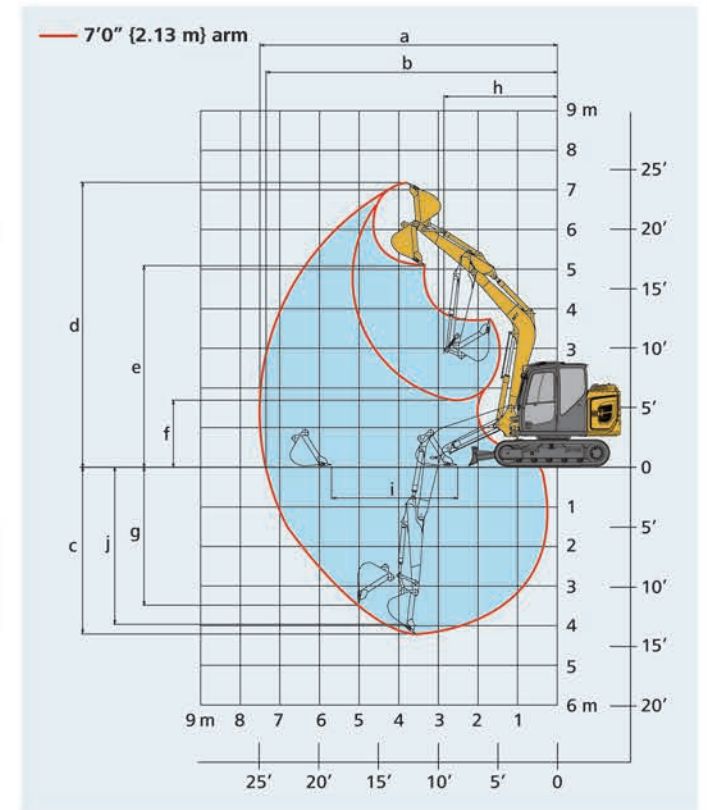

H Tumbler distance	7'3" {2,210}
I Overall length of crawler	9'3" {2,830}
J Track gauge	6'1" {1,850}
K Shoe width**	17.7" {450}/23.6" {600}
L Overall width of upperstructure	7'7" {2,300}

*Without including height of shoe lug **17.7" (450 mm) Rubber tracks, 23.6" (600 mm) Steel shoes

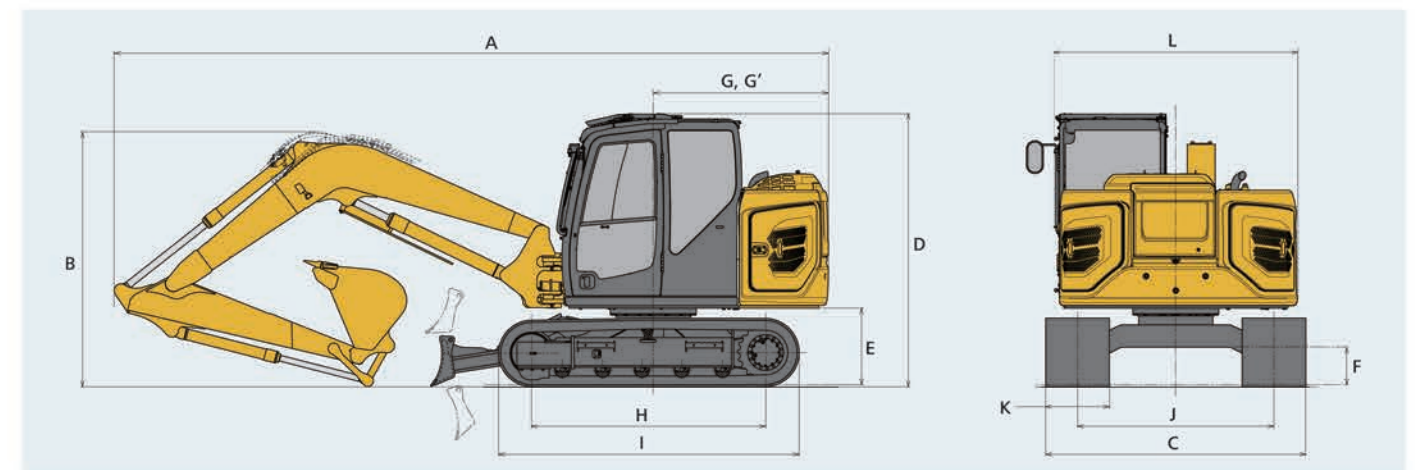

Operating Weight & Ground Pressure

In standard trim, with standard boom, 7'0" {2.13 m} arm, and 0.29 cu.yd. {0.22 m³} ISO heaped bucket

Shaped		Rubber tracks	Steel tracks
Shoe width	ft-in (mm)	17.7" {450}	23.6" {600}
Overall width of crawler	ft-in (mm)	7'7" {2,300}	8'00" {2,450}
Ground pressure	psi (kPa)	5.70 {39}	4.50 {31}
Operating weight	lbs (kg)	19,270 {8,740}	20,100 {9,120}

Lifting Capacities

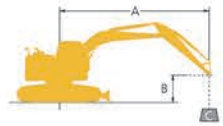

A - Reach from swing centerline
 B - Height above/below ground
 C - Lifting capacities in pounds (kg)
 Relief valve setting: 4,260 psi (29.4 MPa)

SK85CS		Arm: 7'0" (2.13 m) No bucket Standard counterweight Shoe: 17.7" (450 mm) Rubber tracks Dozer: blade down										
		5' (1.5 m)		10' (3.0 m)		15' (4.6 m)		20' (6.1 m)		At max. reach		Radius
B	A	Rating over front	Rating over side or 360 degrees	Rating over front	Rating over side or 360 degrees	Rating over front	Rating over side or 360 degrees	Rating over front	Rating over side or 360 degrees	Rating over front	Rating over side or 360 degrees	
20' (6.1 m)	lb (kg)									*3,320 (1,500)	*3,320 (1,500)	12'6" (3.82 m)
15' (4.6 m)	lb (kg)				*4,130 (1,870)	4,010 (1,810)				*2,610 (1,180)	*2,610 (1,180)	17'11" (5.47 m)
10' (3.0 m)	lb (kg)				*4,770 (2,160)	3,870 (1,750)	*3,250 (1,470)	2,460 (1,110)		*2,510 (1,130)	2,380 (1,070)	20'4" (6.22 m)
5' (1.5 m)	lb (kg)			*10,920 (4,950)	6,410 (2,900)	*6,010 (2,720)	3,610 (1,630)	*4,530 (2,050)	2,380 (1,070)	*2,670 (1,210)	2,180 (980)	21'2" (6.46 m)
G.L.	lb (kg)			*8,680 (3,930)	6,040 (2,730)	*6,770 (3,070)	3,410 (1,540)	*4,630 (2,100)	2,310 (1,040)	*3,140 (1,420)	2,230 (1,010)	20'6" (6.26 m)
-5' (-1.5 m)	lb (kg)	*7,660 (3,470)	*7,660 (3,470)	*10,500 (4,760)	6,040 (2,730)	*6,280 (2,840)	3,370 (1,520)			*4,390 (1,990)	2,600 (1,170)	18'3" (5.57 m)
-10' (-3.0 m)	lb (kg)			*6,130 (2,780)	*6,130 (2,780)					*4,020 (1,820)	*4,020 (1,820)	13'3" (4.05 m)

SK85CS		Arm: 7'0" (2.13 m) No bucket Standard counterweight Shoe: 23.6" (600 mm) Steel tracks Dozer: blade down										
		5' (1.5 m)		10' (3.0 m)		15' (4.6 m)		20' (6.1 m)		At max. reach		Radius
B	A	Rating over front	Rating over side or 360 degrees	Rating over front	Rating over side or 360 degrees	Rating over front	Rating over side or 360 degrees	Rating over front	Rating over side or 360 degrees	Rating over front	Rating over side or 360 degrees	
20' (6.1 m)	lb (kg)									*3,320 (1,500)	*3,320 (1,500)	12'6" (3.81 m)
15' (4.6 m)	lb (kg)					*4,130 (1,870)	*4,130 (1,870)			*2,620 (1,180)	*2,620 (1,180)	17'11" (5.47 m)
10' (3.0 m)	lb (kg)					*4,770 (2,160)	4,020 (1,820)	*3,250 (1,470)	2,570 (1,160)	*2,510 (1,130)	2,480 (1,120)	20'4" (6.22 m)
5' (1.5 m)	lb (kg)			*10,920 (4,950)	6,680 (3,020)	*6,010 (2,720)	3,770 (1,710)	*4,530 (2,050)	2,490 (1,120)	*2,670 (1,210)	2,280 (1,030)	21'2" (6.46 m)
G.L.	lb (kg)			*8,680 (3,930)	6,300 (2,850)	*6,770 (3,070)	3,570 (1,610)	*4,630 (2,100)	2,420 (1,090)	*3,140 (1,420)	2,330 (1,050)	20'6" (6.26 m)
-5' (-1.5 m)	lb (kg)	*7,660 (3,470)	*7,660 (3,470)	*10,510 (4,760)	6,310 (2,860)	*6,280 (2,840)	3,520 (1,590)			*4,390 (1,990)	2,720 (1,230)	18'3" (5.57 m)
-10' (-3.0 m)	lb (kg)			*6,140 (2,780)	*6,140 (2,780)					*4,020 (1,820)	*4,020 (1,820)	13'3" (4.05 m)

- Note:**
- Do not attempt to lift or hold any load that is greater than these lift capacities at their specified lift point radius and heights. Weight of all accessories must be deducted from the above lift capacities.
 - Lift capacities are based on machine standing on level, firm, and uniform ground. User must make allowance for job conditions such as soft or uneven ground, out of level conditions, side loads, sudden stopping of loads, hazardous conditions, experience of personnel, etc.
 - Bucket pin attachment point defined as lift point.
 - The above lifting capacities are in compliance with ISO 10567. They do not exceed 87% of hydraulic lifting capacity or 75% of tipping load. Lifting capacities marked with an asterisk(*) are limited by hydraulic capacity rather than tipping load.
 - Operator should be fully acquainted with the Operator's and Maintenance Instructions before operating this machine. Rules for safe operation of equipment should be adhered to at all times.
 - Lift capacities apply to only machine as originally manufactured and normally equipped by KOBELCO CONSTRUCTION MACHINERY CO., LTD.



Bringing KOBELCO quality to North America and the world

KOBELCO craftsmanship is based on 90 years of experience building excavators with advanced engineering practices and modern inspiration. "Made by KOBELCO" guarantees quality around the world, overseen from our headquarters in Japan. Every KOBELCO excavator is built to the same exacting standards no matter where the excavator is produced.



In 1930, Kobe Steel manufactured Japan's first electric shovel, which was followed by the first hydraulic excavator in 1963. Since then, the KOBELCO brand has become known for groundbreaking machinery that excels at every task from civil engineering to recycling.

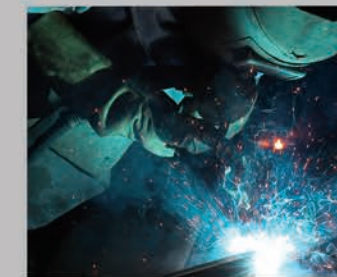

KOBELCO manufacturing is done in multiple production facilities around the world. Since 2016, our plant in Moore, South Carolina has provided assembly, paint, and shipment lines to serve all of North America.

Note: This catalog may contain attachments and optional equipment that are not available in your area. And it may contain photographs of machines with specifications that differ from those of machines sold in your areas. Please consult your nearest KOBELCO distributor for those items you require. Due to our policy of continuous product improvements all designs and specifications are subject to change without advance notice.
Copyright by **KOBELCO CONSTRUCTION MACHINERY CO., LTD.** No part of this catalog may be reproduced in any manner without notice.

KOBELCO CONSTRUCTION MACHINERY U.S.A. INC.

22350 Merchants Way, Katy, TX 77449
Tel: 281-888-8430 Fax: 281-506-8713
www.KOBELCO-USA.com

KOBELCO is the corporate mark used by Kobe Steel on a variety of products and in the names of a number of Kobe Steel Group companies.

Inquiries To:

Bulletin No. SK75SR/SK85CS-NA-201-190300N